



**® ADEMCO**

**Commercial Fire & Burglary Alarm System**

***5120XM***

**Installation Instructions • Installation Instructions • Installation Instructions**

# RECOMMENDATIONS FOR PROPER PROTECTION

The Following Recommendations For The Location Of Fire And Burglary Detection Devices Help Provide Proper Coverage For The Protected Premises.

## Recommendations For Smoke And Heat Detectors

With regard to the number and placement of smoke/heat detectors, we subscribe to the recommendations contained in the National Fire Protection Association's (NFPA) Standard #72 noted below.

Early warning fire detection is best achieved by the installation of fire detection equipment in all rooms and areas of the household as follows: For minimum protection a smoke detector should be installed outside of each separate sleeping area, and on each additional floor of a multi-floor family living unit, including basements. The installation of smoke detectors in kitchens, attics (finished or unfinished), or in garages is not normally recommended.

For additional protection the NFPA recommends that you install heat or smoke detectors in the living room, dining room, bedroom(s), kitchen, hallway(s), attic, furnace room, utility and storage rooms, basements and attached garages.

In addition, we recommend the following:

- Install a smoke detector inside every bedroom where a smoker sleeps.
- Install a smoke detector inside every bedroom where someone sleeps with the door partly or completely closed. Smoke could be blocked by the closed door. Also, an alarm in the hallway outside may not wake up the sleeper if the door is closed.
- Install a smoke detector inside bedrooms where electrical appliances (such as portable heaters, air conditioners or humidifiers) are used.
- Install a smoke detector at both ends of a hallway if the hallway is more than 40 feet (12 meters) long.
- Install smoke detectors in any room where an alarm control is located, or in any room where alarm control connections to an AC source or phone lines are made. If detectors are not so located, a fire within the room could prevent the control from reporting a fire or an intrusion.

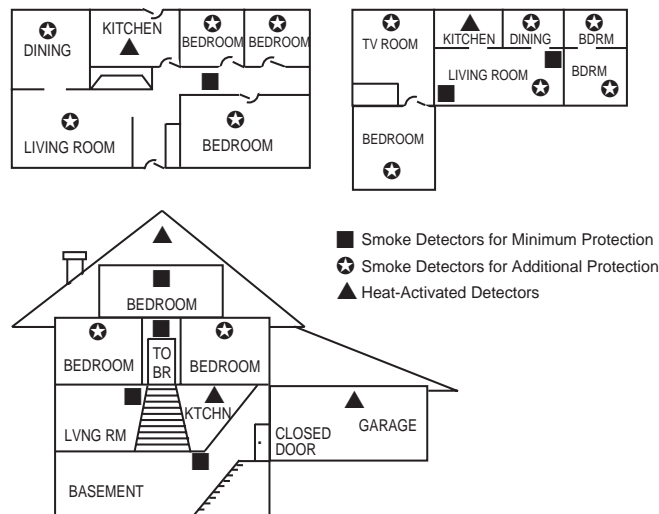

## Recommendations For Proper Intrusion Protection

For proper intrusion coverage, sensors should be located at every possible point of entry to a home or commercial premises. This would include any skylights that may be present, and the upper windows in a multi-level building.

In addition, we recommend that radio backup be used in a security system so that alarm signals can still be sent to the alarm monitoring station in the event that the telephone lines are out of order (alarm signals are normally sent over the phone lines, if connected to an alarm monitoring station).

# TABLE OF CONTENTS

<b>Section 1.</b>	<b>GENERAL DESCRIPTION .....</b>	<b>8</b>
<b>Section 2.</b>	<b>INSTALLING THE CONTROL .....</b>	<b>10</b>
	Mounting the Cabinet .....	10
	Grade A Mercantile Premises Listing.....	10
	Grade A Mercantile Safe & Vault Listing .....	11
	Installing the Lock .....	11
	Installing the Control's Circuit Board .....	11
	Telephone Line Connections .....	12
	Connecting the AC Transformer and Backup Battery.....	13
	Earth Ground Connections .....	13
<b>Section 3.</b>	<b>INSTALLING REMOTE KEYPADS.....</b>	<b>14</b>
	Keypads That May Be Used .....	14
	Wiring To The Keypads .....	14
	Mounting The Keypads .....	15
	Preliminary Check-Out Procedure .....	15
<b>Section 4.</b>	<b>MECHANICS OF PROGRAMMING .....</b>	<b>17</b>
	General Programming Information .....	17
	Entering Program Mode .....	17
	Programming a Data Field .....	17
	Reviewing a Data Field .....	18
	Erasing an Entry in a Data Field .....	18
	Interactive Mode Programming (*56 and *82) .....	18
	Loading Factory Defaults .....	18
	Exiting the Programming Mode .....	18
<b>Section 5.</b>	<b>BASIC HARD-WIRED ZONES 1-5.....</b>	<b>19</b>
	General Information About Hard-Wired Zones .....	19
	Wiring Burglary and Panic Devices to Zones 1-5 .....	19
	Wiring 4-Wire Smoke/Combustion Detectors on Zones 1-5 .....	19
	Zone 4 Tamper Configuration.....	20
	Wiring 2-Wire Smoke Detectors to Zone 5 .....	20
	Turning Off Fire Alarm Sounding.....	21
	Programming Hard-Wired Zones .....	21
	Check-Out Procedure for Hard-Wired Zones .....	23
<b>Section 6.</b>	<b>SYSTEM ZONES .....</b>	<b>24</b>
	General Information .....	24
	System Zone Assignments .....	24
<b>Section 7.</b>	<b>ALARM INDICATING DEVICES .....</b>	<b>25</b>
	General Information .....	25
	Connecting Alarm Indicating Devices .....	25
	Compatible Alarm Indicating Devices .....	26
	Programming External Sounder Options .....	27
<b>Section 8:</b>	<b>AUXILIARY RELAY CONNECTIONS .....</b>	<b>28</b>
	General Information .....	28
	Relay Connections .....	28
	Programming the Auxiliary Relay .....	29
<b>Section 9.</b>	<b>FINAL POWER UP .....</b>	<b>30</b>
	AC Power Connections .....	30
	Earth Ground Connections .....	30
	Powering Up the System.....	31
	Connecting the Back-Up Battery .....	31
	Calculating the Battery Size Needed .....	31
	Total Standby/Alarm Load Worksheets .....	32
	Making the Battery Connections .....	35
	Battery Supervision .....	35

<b>Section 10. ALPHA DESCRIPTION PROGRAMMING</b> .....	36
Assigning Zone Descriptors .....	36
Entering Zone Descriptors (in program Menu Mode *82) .....	36
Programming the Descriptors .....	36
Alternate Method for Programming Zone Descriptors .....	38
Adding Custom Words .....	39
Alpha Vocabulary List (For Entering Zone Descriptors) .....	40
Character (ASCII) Chart .....	41
<b>Section 11. SYSTEM COMMUNICATION</b> .....	42
General Information .....	42
Report Code Formats .....	42
Table of Contact ID Codes .....	44
Programming Communication Options .....	45
<b>Section 12. ZONE RESPONSE TYPE DEFINITIONS</b> .....	50
<b>Section 13. DATA FIELD DESCRIPTIONS</b> .....	53
Description of System Data Fields .....	53
<b>Section 14. REMOTE PROGRAMMING AND CONTROL (DOWNLOADING)</b> .....	61
General Information .....	61
Equipment Required .....	61
Initial Download .....	61
Remote Programming Information .....	62
Remote Programming Advisory Notes .....	62
<b>Section 15. SYSTEM OPERATION</b> .....	63
User Codes .....	63
Master Code .....	63
Secondary User Codes .....	63
Keypad Functions .....	64
Arming Functions .....	64
Panic Keys .....	65
<b>Section 16. TESTING THE SYSTEM</b> .....	66
Battery Test .....	66
Dialer Test .....	66
Fire Drill Test .....	66
One Man Fire Walk Test .....	66
Burglary Walk Test .....	67
Armed Burglary Test .....	67
Trouble Conditions .....	68
General Information .....	68
"Check" and "Battery" Displays .....	68
Telephone Line Failure .....	68
Power Failure .....	68
Other Displays (Fixed Word Keypads) .....	68
Turning the System Over to the User .....	69
To the Installer .....	69
<b>Section 17. TROUBLESHOOTING GUIDE</b> .....	70
Contacting Technical Support In The Event Of Problems .....	71
<b>Section 18. SPECIFICATIONS &amp; ACCESSORIES</b> .....	72
Specifications .....	72
Accessories (Compatible Devices) .....	73
<b>SUMMARY OF SYSTEM COMMANDS</b> .....	75
<b>REGULATORY AGENCY STATEMENTS</b> .....	76
<b>LIMITATIONS OF THIS ALARM SYSTEM</b> .....	78
<b>LIMITED WARRANTY</b> .....	79
<b>INDEX</b> .....	80
<b>5120XM SUMMARY OF CONNECTIONS DIAGRAM</b> .....	Inside Back Cover
<b>PROGRAMMING FORM</b> .....	Centerfold

# LIST OF FIGURES

Figure 1: Cabinet Attack Resistance Considerations .....	10
Figure 2. Installing the Cabinet Lock.....	11
Figure 3. Mounting The PC Board .....	12
Figure 4. 4-Wire Smoke Detector Connections (Zones 1–5) .....	20
Figure 5. 2-Wire Smoke Detector Connected to Zone 5 .....	21
Figure 6. Making Bell Circuit Connections Using Input and Output B of the PS24 Power Supply Module.....	25
Figure 7. Wiring the Auxiliary Relay Output for Burglary Alarm Devices .....	28
Figure 8. Wiring the Auxiliary Relay Output for 4-Wire Smoke Detector Power Usage .....	28
Ademco 5120XM Summary of Connections Diagram .....	Inside Back Cover

# HOW TO USE THIS MANUAL

This manual is written to accommodate both the new and the experienced installer of Ademco products. A general description of the entire system is located at the beginning of the manual. The wiring and physical setup of the hardware follows.

The sections at the core of the manual include both hardware setup and programming requirements of each device to make that specific device operational in the system. A checkout procedure is included at the end of each section. We recommend this method to ensure that each device is working properly before proceeding to the next section. It must also be used if you are making a particular addition to the system of one of these devices.

Each of the sections covering the installation of peripheral devices includes the programming for that device. Without an understanding of the programming methodology, you will not be able to successfully perform the required programming in each of these sections. We therefore urge you to read *Section 4: MECHANICS OF PROGRAMMING* before any programming is performed.

If you are an experienced user of Ademco products, you may choose to wire and then program the entire system at once. If so, refer to *Section 4: MECHANICS OF PROGRAMMING* and *Section 13: DATA FIELD DESCRIPTIONS* after the hardware setup is complete. A blank pull-out programming form is included with this manual.

This manual uses various icons to denote critical notes and technical tips to assist you with the installation of this system. These are easily seen in the left-hand column of the relevant information.

# CONVENTIONS USED IN THIS MANUAL

## MAIN SECTION TITLES ARE SHOWN IN REVERSE TYPE

Before you begin using this manual, it is important that you understand the meaning of the following symbols (icons).

	These notes include specific information which must be followed if you are installing this system for a UL Listed application.
---	--

	These notes include information that you should be aware of before continuing with the installation, and which, if not observed, could result in operational difficulties.
---	--

	This symbol indicates a critical note that could seriously affect the operation of the system, or could cause damage to the system. Please read each warning carefully. This symbol also denotes warnings about physical harm to the installer.
---	---

Enter Zn Num. (00 = Quit)                      01
--

Many system options are programmed in an interactive mode by responding to Alpha keypad display prompts. These prompts are shown in a double-line box.

\*00

When programming the system, data fields are indicated by a "star" (\*) followed by the data field number.

**PRODUCT MODEL NUMBERS:** Unless noted otherwise, references to specific model numbers represent Ademco products.

# Section 1. GENERAL DESCRIPTION

The Ademco 5120XM is a UL listed fire/burglary control which provides the features outlined below.

## Basic Hardwired Zones

Provides 5 style B (for further explanation of style B, refer to NFPA 72 National Fire Alarm Code Chapter 3: Protected Premises Fire Alarm Systems) hardwired zones having the following characteristics:

- EOLR supervision supporting N.O. or N.C. sensors
- 300 – 500ms response time
- Individually assignable to bell output and/or aux. relay
- Supports up to 16 2-wire smoke detectors on Zone 5
- Supports 4-wire smoke detectors on any zone (power to these should be supplied from the control's auxiliary relay power output; see the section on *Hardwired Zones*)
- Tolerance of 300-ohm resistance on zones 1-4, 100-ohm resistance on zone 5 (excluding EOLR)

## Remote Keypads

Up to 4 of any of the following keypads may be used :

*Fixed-Word Keypads:* 6137 (gray) or 6137R (red)

*Alpha Keypads:* 6139 (gray) or 6139R (red)



A 6139 or 6139R keypad must be used to for keypad programming. However, these keypads need not remain in the installation provided at least one 6137 or 6137R is installed.

## User Codes

- 1 Master code for entire system (user 1– intended for use by installer)
- 5 secondary user codes (users 2–6; user 2 intended for use by principle end user)
- 1 duress code (user 8)



**Duress Code:** An emergency code which, when entered by *any* user to disarm or arm the system, will send a silent duress message to the central station (useful only if report code is programmed for Zone 8).

## Keypad Panic Keys

Provides up to 3 programmable panic key functions:

- Designated as Zones 7, 95, and 96
- Can be programmed for 24-hr. silent, audible, auxiliary, or fire responses

## Backup Dialer

Has built-in backup dialer for connecting to a second supervised telephone line.

## Bell Outputs

Provides one Style Y (class B) (for further explanation of style Y, refer to NFPA 72 National Fire Alarm Code Chapter 3: Protected Premises Fire Alarm Systems), supervised bell output.



### Auxiliary Relay

Provides a built-in 12V wet or dry (jumper selectable) "Form C" relay which can be used for one of the following:

- Alarm activation on selected zones, silenced by Code + Off
- Trouble/Supervisory activation
- 4-wire smoke detector reset
- Battery saving feature (disconnects power from non-critical loads 4 hours after AC power loss)
- Alarm activation on selected zones, silenced by Code + #67 (can be used for elevator recall)

### 24-Volt Power Supply

Includes the PS24 Power Supply Module, which:

- Supplies two 24VDC, 1.7A full-wave rectified, unfiltered outputs, to be used as follows:
  - One is used to power alarm notification appliances (sirens, strobes, etc.)
  - One is used to power 24V auxiliary devices (optional)

### Programming

Programmed options are stored in electrically erasable, non-volatile EEROM memory (information can be reprogrammed at any time and will not be lost in the event of a power loss). The system can be programmed by one of the following methods:

- Uploaded, downloaded, or controlled via an IBM compatible computer, V-Link software and a HAYES modem specified by Ademco
- Programmed through an alpha keypad (6139, 6139R)

**UL**

Remote programming may only be used when a service technician is at the site during downloading.

Keypad programming consists of:

- Data field programming
- Interactive (menu) mode programming



A 6139 or 6139R keypad must be used to for keypad programming. However, these keypads need not remain in the installation provided at least one 6137 or 6137R is installed.

### Communication Formats Supported

- Ademco Low Speed (Standard or Expanded)
- SESCOA/Radionics (Standard or Expanded)
- Ademco Express
- Ademco Contact ID

### Agency Listings

#### Fire:

- UL864-NFPA 72 Local, Central Station and Remote Station fire alarm service
- FM Pending
- CSFM Pending

#### Burglary:

- UL609 Grade A Local Mercantile Premises and Mercantile Safe and Vault
- UL611/UL1610 Grade B Central Station Burglary Alarm Service (Grade A service will be available with future 7720PLUS LORRA)
- UL365 Grade A Police Connect Burglary Alarm Service

## Section 2. INSTALLING THE CONTROL

This section provides instructions for mounting the control cabinet, and installing the cabinet lock. Also included in this section are instructions for the following:

- Installing the main PC board
- Making phone line connections
- Installing the back-up battery in the cabinet
- Connecting the AC transformer and battery
- Making earth ground connections

### Mounting the Cabinet

Mount the control cabinet to a sturdy wall using fasteners or anchors (not supplied), in a clean, dry area that is not readily accessible to the general public. Four mounting holes are provided at the back of the cabinet.

### Grade A Mercantile Premises Listing

- The panel door must be supervised. Mount the clip-on tamper switch (supplied) to the cabinet's right side wall as shown in the diagram below and wire it to zone 4.
- Use a burglary bell with a tamper protected housing such as the Ademco AB12. The bell housing's tamper switch and inner tamper linings must also be wired to zone 4.

	<b>Burglary alarm bells should be powered from the control's auxiliary relay power output.</b>
---	--

- Program zone 4 for day trouble/night alarm (type 5, field \*56) response and enable the zone 4 alternate tamper function (field \*36).
- All wiring between the bell and panel must be run in conduit. Remaining wires do not need to be run in conduit.
- All wiring which is not run in conduit must exit from the knock-out openings on the bottom or back of the cabinet.
- All unused knockouts must be plugged using the disc plugs and carriage bolts, supplied, as indicated in the diagram below
- Fasten the cabinet door to the cabinet backbox using the 18 one inch long Philips head screws (supplied) after all wiring, programming and checkout procedures have been completed

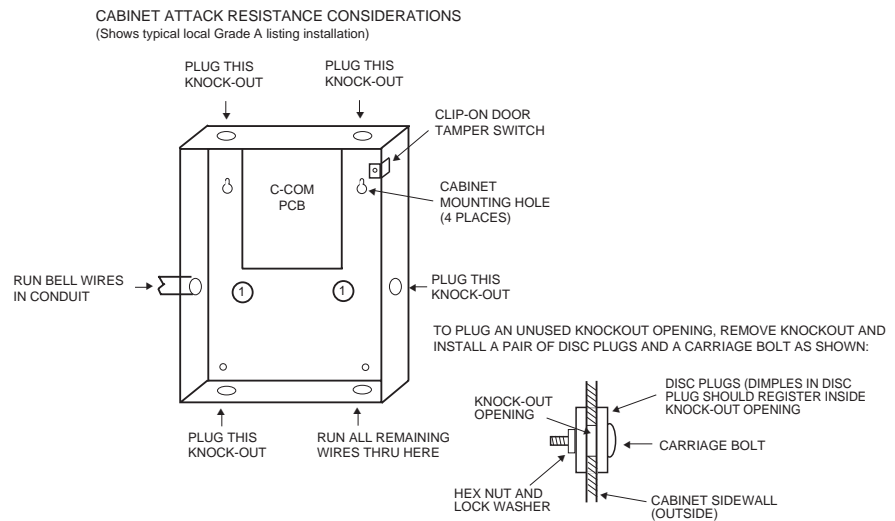

**Figure 1: Cabinet Attack Resistance Considerations**

## Grade A Mercantile Safe and Vault Listing

- Follow the instructions given above for Mercantile Premises listing.
- In addition, mount a shock sensor such as Sentrol No. 5402 to the panel's backbox. Follow the manufacturer's instructions for proper sensor mounting. Also, a UL listed contact must be used inside the cabinet through one of the knock-outs for pry-off purposes. Wire the shock sensor and pry-off tamper contact to zone 4.

### Installing the Lock

Use an Ademco No. N6277 Cam Lock and No. N3422-2 Push-On Retainer Clip.

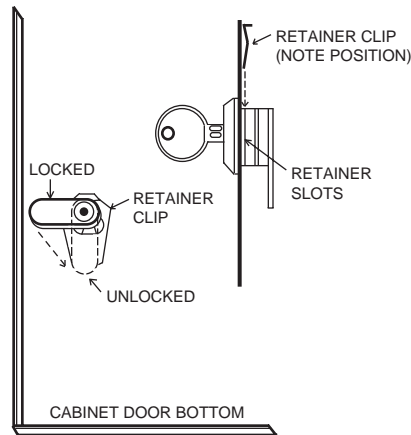

1. Remove the cabinet door. *It is easily removable for servicing and is easily re-installed.*
2. Insert the key into the lock. Position the lock in the hole making certain that the latch will make contact with the latch bracket when the door is closed.
3. Hold the lock steady, and insert the retainer clip into the retainer slots. Position the clip as illustrated in order to permit easy removal.

**Figure 2: Installing The Cabinet Lock**

### Installing the Control's Circuit Board

Refer to Figure 3 when mounting the PC board.

- Hang the three mounting clips on the raised cabinet tabs. Be sure the clip orientation is exactly as shown in the diagram to avoid damage to the clip when mounting screws are tightened. This will also avoid problems with insertion and removal of the PC board.
- Insert the top of the circuit board into the slots at the top of the cabinet. Be sure that the board rests in the slots as indicated in step A detail.
- Swing the base of the board into the mounting clips and secure the board to the cabinet with the accompanying screws.



Be sure that the mounting screws are tight. This ensures that there is a good ground connection between the PC board and the cabinet. Also, dress field wiring away from the microprocessor (center) section of the PC board. Use the 2 loops on the left and right sidewalls of the cabinet for anchoring field wiring using tie wraps. These steps are important to minimizing the risk of panel RF interference with television reception.

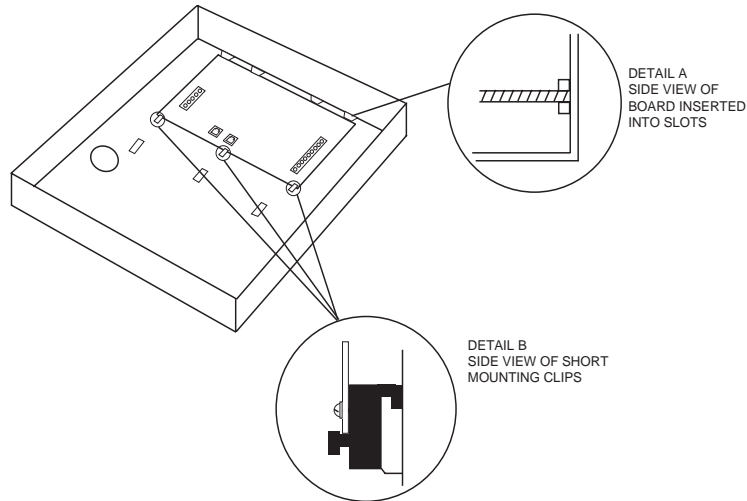



**Figure 3. Mounting The PC Board**

### Telephone Line Connections

The 5120XM provides two supervised dialer outputs referred to as the main and backup dialers. In fire installations, both outputs must be connected to separate telephone lines providing loop start service.

Connect the main dialer and back-up dialer (if used) outputs to telephone company lines using the RJ31X cables supplied. *Do not* connect to telephone company lines which provide ground start service.

	<b>DO NOT</b> connect both outputs to the same telephone line. A secondary phone line is required in case of primary phone line failure.
---	--

- |   |   |
|---|---|
|  | <ol style="list-style-type: none"> <li>1. To prevent the risk of shock, disconnect phone lines at telco jack before servicing the panel.</li> <li>2. If the control is connected to a telephone line inside a PABX, be sure the PABX has a back-up power supply that can support the PABX for 24 hours (Central Station usage) or 60 hours (Remote Station usage). Many PABXs are <i>not</i> power backed and connection to such a PABX will result in a communication failure if power is lost.</li> </ol> |
|---|---|

### Enabling the Dialer Outputs

To enable the dialer outputs, entries must be made in field \*79. Enter 1 in the first entry space to enable the main dialer. Enter 1 in the second entry space to enable the backup dialer.

### Telephone Line Supervision

The supervision circuits on both the main and backup dialer outputs will indicate a fault when the tip/ring voltage falls below 2 volts, provided that their supervisory zones are enabled (zones 11 and 12, respectively). These zones are enabled in field \*56 and should be assigned a response type of 19 (24-hr. trouble).

	In fire installations, both outputs must be configured for line fault supervision.
---	--

## Dialer Operation

When only the main dialer is enabled ([1,0] in field \*79), the 5120XM will attempt to route all calls over the main output. When both main and back-up dialers are enabled ([1,1] in field \*79), the 5120XM will attempt to route all calls over the main output until a fault is detected, at which time it will attempt to use the back-up output. Line faults will result in a Zone 11 MAIN DIALER FAULT or a Zone 12 BACKUP DIALER FAULT display. The control will make up to 5 attempts to transmit a report to the primary number and 5 attempts to the secondary if both numbers are programmed. If only the primary number is programmed, the control will make 10 attempts to that number. After the tenth attempt, the control will hang up and a COMM FAIL will be displayed at the keypad.

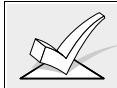

The system will not switch to the back-up dialer unless it detects a fault (less than 2 volts) on the main telephone line. This means that if a report does not go through on the main phone line due to a programming error, the back-up dialer will **not** be activated.

The 5120XM will transmit reports in the following order: alarms (fire, medical/panic, burglary), fire supervisory and troubles, remaining types of messages. See the *SYSTEM COMMUNICATION* section for a description of communication formats, the types of messages transmitted by the panel, and for the dialer programming defaults.

## Connecting the AC Transformer and Backup Battery

Due to the nature of this product, the transformer must be hardwired into the premises electrical system. Therefore, we recommend wiring all zones and expansion modules according to each section's instructions *before* powering up the system for programming and testing. Refer to *Section 9: FINAL POWER UP* for specific instructions on how to connect the AC transformer and battery.

If desired, you can wire, program, and test each section individually by temporarily powering up the control for programming and testing each section before final power up.

## Earth Ground Connections



The 5120XM requires connection to a good earth ground in order to provide proper 120VAC shock hazard protection, lightning transient protection, and earth ground fault detection.

Refer to the National Electrical Code for proper earth grounding methods.

To make earth ground connections, do the following:

1. Run an earth ground wire into the transformer enclosure via the same knockout used for 120VAC wiring.
2. Use a wire nut (not supplied) to splice this earth ground wire to the green flying lead located inside of and bonded to the transformer enclosure. Push the mated wires into the enclosure.
3. Connect the green flying lead which emerges from the top of the transformer enclosure to the 5120XM's earth ground terminal (Terminal 8). Make a connection between this terminal and the PS24's earth ground terminal (Terminal 3).
4. Replace the transformer enclosure cover after wiring is complete.

## Section 3. INSTALLING REMOTE KEYPADS

This section provides the following information:

- A list of keypads that may be used
- Instructions for wiring and mounting the keypads
- A preliminary check-out procedure to ensure that the keypads are functioning properly in the system

### Keypads That May Be Used

- Fixed-Word Displays: 6137, 6137R
- Alpha Displays: 6139, 6139R



1. A 6139 or 6139R keypad must be used for keypad programming. However, these keypads need not remain in the installation provided at least one 6137 or 6137R is installed.
2. Many municipalities require fire annunciation devices (keypads included) to be red in color. Check with the authority having jurisdiction before selecting a keypad color for your installation.

A total of 4 keypads may be used, provided that the 400mA current rating for Aux. Power #1, Aux. Power #2, and for the system as a whole is not exceeded. Fixed word and alpha keypads may be used in the same installation.

Multiple keypads may be wired to a single wire run or each may be connected to a separate wire run back to the control panel using 4-conductor cable. Follow the maximum wire lengths per gauge defined in the chart below, taking into consideration the current draw on each wire run.



The total length of all wire runs combined must not exceed 900 feet when unshielded cable is used (450 ft. if shielded cable is used).

Wire Size	100mA	200mA	300mA	400mA
#22	250 ft.	125 ft.	80 ft.	60 ft.
#20	400 ft.	200 ft.	130 ft.	100 ft.
#18	625 ft.	310 ft.	200 ft.	150 ft.
#16	900 ft.	450 ft.	300 ft.	225 ft.

*Example:* If you have two keypads on one wire run that draw a total of 200 mA, and you are using #20 AWG wire, the distance from the control panel Aux + and - terminals to the last device can be up to 200 ft.

### Wiring To The Keypads

The 5120XM provides two keypad interface ports. Keypad Port 1 is located on terminals 17-20 of the terminal block; Keypad Port 2 is located on pins 1, 4, 5, and 7 of the J5 header..

1. Run field wiring from the control to the keypads (using standard 4-conductor twisted wire cable.



If using only one keypad, you may connect it to either Keypad Port 1 or 2, but it must be mounted on the cabinet or on an electrical box within 3 ft. of the cabinet with the wiring run in conduit. When using more than one keypad, you must connect one keypad to Keypad Port 2 and mount it on the cabinet or on an electrical box within 3 feet of the cabinet with the wiring run in conduit. Additional keypads can be mounted where desired and connected to Keypad Port 1 terminals. The keypad on Port 2 is electrically isolated from those on Port 1 and will continue to function even if wiring problems prevent the other keypads from working properly.

2. Connect the main keypad to Keypad Port 2 as follows, using the 4142TR cable (supplied):

<b>J5 Header</b>	<b>Keypad Wire</b>
Pin 1	Black (Ground)
Pin 4	Green (Data In)
Pin 5	Red (Aux Power #2 +)
Pin 7	Yellow (Data Out)

3. Connect remote keypads to the control terminal board as follows:

<b>Terminal Screw</b>	<b>Keypad Wire</b>
17	Red (Aux Power #1 +)
18	Black (Ground)
19	Green (Data In)
20	Yellow (Data Out)

### **Mounting the Keypads**

1. Make sure keypads are set to non-addressable mode (address 31), which is the factory default setting. If you suspect the address setting is incorrect (keypads are non-operational), refer to the instructions provided with the keypad for address setting procedure.
2. Mount the keypads at a height that is convenient for the user. Refer to the instructions provided with the keypad for mounting procedure.  
You can either surface mount or flush mount 6139(R) keypads (using an appropriate Trim Ring Kit: 6139TRK). The 6137(R) keypads can be surface mounted only. Refer to the mounting instructions and template included with the keypad and/or trim ring kit for specific information.

### **Preliminary Check-out Procedure**

If you want to check that the system is working before connecting field wiring from zones and devices, do the following:

1. Temporarily connect a 2K-ohm end-of-line resistor across each of the basic hard-wire zones 1–5, as shown in the Summary of Connections diagram.  
Without actual zone wiring or EOL resistors connected, the keypads in the system will not display the “Ready” message.
2. Power up the system temporarily.
3. **Busy – Standby** (Alpha keypads) or **Not Ready** (Fixed-word keypads) will be displayed.

**After approximately 1 minute\***, the green “READY” LED should light, and Fixed-word keypads should display the word AC. Alpha keypads should display DISARMED...READY TO ARM (if burglary features are enabled) or SYSTEM NORMAL (if burglary features are disabled).

\* To bypass the 1-minute delay, press # plus 0.

If the “Ready” display does not appear on any of the keypads in the system or a “Not Ready” message is displayed, check the keypad wiring connections, and make sure each of the 5 hard-wired zones has a 2K-ohm resistor connected across its terminals.

4. When you get the proper “Ready” displays on the keypad(s), the system is functioning properly at this point.

Do not remove the EOL resistors until you are ready to make connections to the hard-wired zones, to allow for testing later in the installation.



If an OC or OPEN CIRCUIT is present on the keypad, data from the control is not reaching the keypad. Please check the wiring.



## Section 4. MECHANICS OF PROGRAMMING

This section provides the following information:

- How to enter and exit the programming mode
- How to program a data field
- How to review an entry in a data field
- How to erase an entry in a data field
- How to program user-friendly interactive modes (\*56, \*82)
- Loading factory defaults

### General Programming Information

Characteristics for each installation are stored in non-removable, electrically erasable, non-volatile EEROM memory. These must be programmed for the particular installation to establish its specific alarm and reporting features.

It is possible to program the system at any time, even at the installer's premises prior to the actual installation. Simply apply power temporarily to the control and then program the unit as desired.



There are two programming modes: data field programming and interactive (menu) mode programming. Data field programming is used for setting various system options and interactive programming is used for programming zone information.



A 6139 or 6139R keypad must be used to for keypad programming. However, these keypads need not remain in the installation provided at least one 6137 or 6137R is installed.

Programming can also be performed remotely from the installer's office/home, using an IBM personal computer, a modem, and V-Link downloading software. See the *REMOTE PROGRAMMING AND CONTROL (DOWNLOADING)* section.

### Entering Program Mode

You may use one of the following methods:

- a) Press both the [\*] and [#] keys at the same time **within 50 seconds after power is applied to the Control**, or
- b) After power up, enter the Master code (**5 1 2 0**) + **8 0**.

This method is disabled if you exit the program mode using \*98 instead of \*99. See "Exiting Program Mode" paragraph later in this section.

If a different Master code is subsequently programmed, use it instead of 5120 to gain access to the Programming mode.

Following entry into program mode, data field \*20 will be displayed (this is the first field in the system). The system will now accept entries for field \*20.

### Programming a Data Field

1. Press [\*] plus **Field No.** (for example, \*21); then make the required entry.
2. When you have completely programmed a data field, the keypad will "beep" three times and then automatically display the next data field in sequence. To go to a different field, press [\*] plus the desired field No.
3. If the number of digits that you need to enter in a data field is less than the maximum digits available (for example, the phone number field), enter the desired data, then press \* and the next data field number to be programmed.
4. If you try to enter a non-existent field, the keypad will display **EE or Entry Error**. Simply re-enter [\*] plus a valid field number.

## Reviewing a Data Field

Press [#] plus **Field No.** Data will be displayed for that field number. **No changes will be accepted in this mode.**

## Erasing an Entry in a Data Field

To delete an entry in a field, press [\*] plus **Field No.** + [\*]. (Applies only to fields \*40–\*43, and \*94).

## Interactive Mode Programming (\*56 and \*82)

Typical prompt displayed during interactive mode programming

```
Enter Zn Num.  
(00 = Quit) 01
```

Zone Number ↑

Press [\*] plus **interactive mode No.** (for example, \*56). The Alpha keypad will display the first of a series of prompts requesting entries.

Make entries, and then press \* to continue. To back up one screen, press the # key.

A detailed procedure (with displays of prompts) is provided in those sections where programming in the interactive mode is to be performed.

Interactive Mode	Used To Program
*56 Zone Programming	Zone characteristics, report codes, and alpha descriptors.
*82 Alpha Programming	Zone alpha descriptors

## Loading Factory Defaults

To load the factory defaults, enter the programming mode, press \*97, and then exit the programming mode.



Do not press \*97 to load defaults if any programming has been done previously—data already programmed into the system will be changed!

**\*96** resets the Subscriber Account number and CSID in preparation for an initial download. If using this, this must be done **after** \*97 if loading factory defaults.

## Exiting the Programming Mode

**\*99** allows re-entry into the program mode using **Master Code + 8 0**.

**\*98** inhibits re-entry into the programming mode using the Master code.

## Section 5. BASIC HARD-WIRED ZONES 1-5

This section provides the following information:

- General information about hardwired zones
- Installing 2-wire smoke detectors
- Installing 4-wire smoke/combustion detectors
- Programming hardwired zones
- Checkout procedure for hardwired zones

### General Information about Hardwired Zones

Provides 5 Style B supervised hardwired zones having the following characteristics:

- EOLR supervision supporting N.O. or N.C. sensors, including:
  - fire alarm sensors (N.O. only)
  - 24-hr. alarm sensors
  - burglary sensors
  - fire sprinkler supervisory sensors
- 300 – 500ms response time
- Individually assignable to bell output and/or aux. relay
- Supports up to 16 2-wire smoke detectors on Zone 5
- Supports 4-wire smoke detectors on any zone (power to these should be supplied from the system's auxiliary relay power output; see *Installing 4-Wire Smoke Detectors* later in this section).
- Tolerance of 300-ohms on Zones 1-4, 100-ohms on Zone 5 (excluding EOLR)



Use the model #610-7 2k EOLR's (supplied) on zones programmed for fire alarm or fire supervisory response. Use the standard 2k EOLRs (supplied) on zones programmed for panic and burglary alarm responses.

### Wiring Burglary and Panic Devices To Zones 1- 5

1. Connect sensors/contacts to the hardwired zone terminals (see the Summary of Connections diagram).
2. Connect closed circuit devices in series on the high (+) side the loop. The EOL resistor must be connected in series with the devices, following the last device (see the Summary of Connections diagram).
3. Connect open circuit devices in parallel across the loop. The 2K-ohm EOLR must be connected across the loop wires *at the last device*.



If the EOLR is not at the end of the loop, the zone will not be properly supervised, and the system may not respond to an open circuit on the zone.

### Wiring 4-Wire Smoke/Combustion Detectors on Zones 1-5

The system will support as many 4-wire detectors as can be powered from Auxiliary Relay Power on Zones 1-5. Refer to the detector's instructions for complete details regarding its proper installation and operation.

1. Connect 12-volt power for the detectors from the Auxiliary Relay Output, (which can be programmed to interrupt power for fire alarm reset). Observe proper polarity when connecting detectors.
2. Connect detectors (including heat detectors, if used) across terminals of the zone selected. All detectors must be wired in parallel.

 Remove the 2000 ohm EOL resistor if connected across the zone terminals, and connect it across the loop wires at the last detector.

3. **Power to the smoke detectors must be supervised in fire installations.** To supervise power, we recommend the use of a System Sensor No. A77-716B supervisory module.

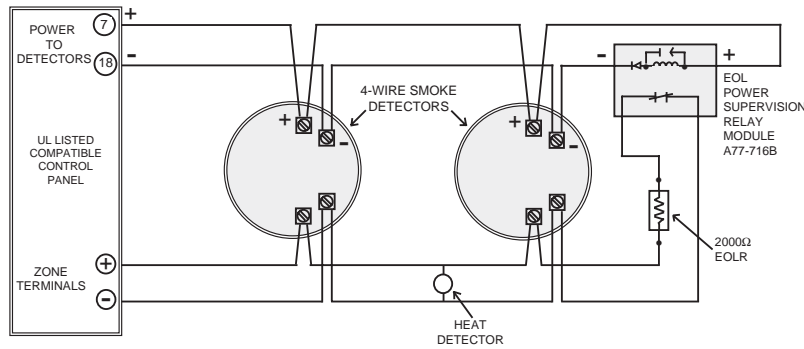

Four-Wire Detector Circuit

**Figure 4: 4-Wire Smoke Detector Connections (Zones 1-5).**

COMPATIBLE 4-WIRE SMOKE/COMBUSTION DETECTORS	
<b>1412</b>	<i>System Sensor, 4-wire ionization products of combustion detector</i>
<b>2412</b>	<i>System Sensor, 4-wire photoelectric smoke detector</i>
<b>2412TH</b>	<i>System Sensor, 4-wire photoelectric smoke detector w/135° F (57° C) heat detector</i>
<b>2112/24T</b>	<i>System Sensor low-profile 4-wire photoelectric smoke detector w/135° F (57° C) heat detector</i>

**Zone 4 Tamper Configuration**

Zone 4 may be used as a tamper loop for the 5120XM cabinet door tamper switch and for the Ademco AB12 Grade A burglary bell box tamper switches and tamper liner. To program Zone 4 as a tamper, set program field \*36 to "1" and program Zone 4 for zone response type 5 (Trouble-by-Day/Alarm-by-Night).

When set in this manner, the zone will trigger a trouble when the panel is disarmed and an alarm when the panel is armed, when the zone senses either an open or a short, or when an earth ground fault caused by drilling through the AB12 housing is detected. See the section on *EXTERNAL SOUNDERS* for information on AB12 bell wiring.

**Wiring 2-Wire Smoke Detectors To Zone 5**

1. Connect up to 16 2-wire smoke detectors across Zone 5 terminals (2mA standby current available). Observe proper polarity when connecting the detectors.

 Due to the alarm current available on zone 5, only one smoke detector at a time can be supported in the alarmed state.

2. If an EOL resistor is presently connected across zone 1 terminals, remove it. **The EOL resistor must be connected across the loop wires at the last detector.**
3. See "Programming Hard-Wired Zones" later in this section for a detailed programming procedure.

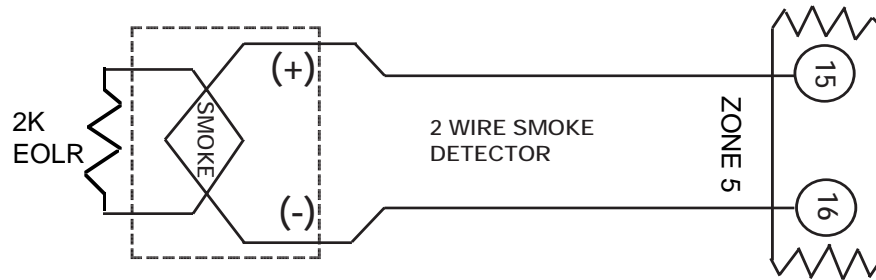

**Figure 5: 2-Wire Smoke Detector Connected to Zone 5**

<b>COMPATIBLE 2-WIRE SMOKE DETECTORS</b>	
<b>Detector Type</b>	<b>Device Model #</b>
Ionization, direct wire	System Sensor 1100
Ionization with B110LP base	System Sensor 1151
Ionization, direct wire	System Sensor 1400
Ionization w/B401B base	System Sensor 1451
Ionization duct detect. w/DH400 base	System Sensor 1451DH
Photoelectric, direct wire	System Sensor 2100
Photoelectric w/heat sensor, direct wire	System Sensor 2100T
Photoelectric w/B110LP base	System Sensor 2151
Photoelectric w/heat sensor, direct wire	System Sensor 2300T
Photoelectric, direct wire	System Sensor 2400
Photoelectric w/heat sensor, direct wire	System Sensor 2400TH
Photoelectric w/B401B base	System Sensor 2451
Photoelectric w/heat sensor & B401Bbase	System Sensor 2451TH
Photoelectric duct detector w/DH400 base	System Sensor 2451

**Note: Mixing of the above types of smoke detectors on zone 5 is permitted.**

### **Fire Alarm Verification for Smoke Detectors**

This feature applies to 2-wire smoke detectors wired to Zone 5 when set to response type 16. It also applies to 4-wire smoke detectors wired to any zone set to response type 16, provided that the detectors are powered from the auxiliary relay power output (field \*34 must be set to "2").

The control panel will "verify" any alarm by resetting the smoke detectors after the first alarm trigger, and then waiting 90 seconds for a second alarm trigger. If the smoke detector or thermostat does not trigger again, the control will disregard the first trigger, and no alarm signal will occur. This feature eliminates false alarms due to electrical or physical transients.

### **Turning Off Fire Alarm Sounding**

You can turn off fire alarm sounding by entering the [User Code] + OFF on any keypad. To clear the "memory of alarm" and to reset the detector's alarm, enter the [User Code] + OFF again.

### **Programming Hard-Wired Zones**

1. With at least one 2-line Alpha keypad (6139/6139R) connected to the keypad terminals on the control, power up the system temporarily.
2. Enter the programming mode by keying the following on the Alpha keypad: **Master code (5 1 2 0) + 8 0.**
3. **Press \*56.** Note that this is an interactive programming mode. You will use it to program zone numbers, zone types and alarm report codes for

hard-wired zones.

Enter Zn Num.	
(00 = Quit)	01

Zone Number ↑

Typical summary display

Zn	ZT	RC
01	09	00

↓ Zone Number

01 Zone Type
Fire 09

Zone Type ↑

Upon entering \*56 mode, this prompt will be displayed. Enter the first zone number that you wish to program (or [0][0] to exit zone programming). If you are starting with zone 1, enter "01". Press \* to continue.

A summary display will appear, showing the present status of that zone's programming.

**Zn** = zone number;  
**ZT** = zone type;  
**RC** = report code for that zone;

Values displayed are currently programmed values.

If the zone is programmed satisfactorily, press [#] to back up one step and enter the next zone number, if desired.

If you want to change a zone's programming, press [\*]. A prompt for Zone Type will appear.

Each zone must be assigned a zone type, which defines the way in which the system responds to faults in that zone. A detailed explanation of each zone type is provided in "Response Type Definitions" in *Section 12: ZONE RESPONSE TYPE DEFINITIONS*.

Enter the desired zone type code, as listed below.

- |                              |                                 |
|------------------------------|---------------------------------|
| 00 = Zone Not Used           | 09 = Fire Without Verification. |
| 01 = Entry/Exit Burglary     | 10 = Interior w/Delay           |
| 02 = not used                | 16 = Fire With Verification     |
| 03 = Perimeter Burglary      | 17 = Fire Waterflow             |
| 04 = Interior, Follower      | 18 = Fire Sprinkler Supervisory |
| 05 = Trouble Day/Alarm Night | 19 = 24-Hr. Trouble             |
| 06 = 24 Hr Silent            |                                 |
| 07 = 24 Hr Audible           |                                 |
| 08 = 24 Hr Aux               |                                 |

When the display shows the zone type you want, press [\*] to continue.

	You must enter "00" as the <b>zone type</b> for any hard-wired zones that are not used.
---	---

01 Report Code		
1st 03	2nd 12	3C

The report code consists of 2 hexadecimal digits, each in turn consisting of 2 numerical digits. For example, for a report code of "3C", enter [0][3] for "3" and [1][2] for "C". Refer to *Section 11: SYSTEM COMMUNICATION* for complete information on report codes, if necessary.

Enter the desired report code and then press [\*] to continue.

The summary screen will now reappear, showing the programming changes for that zone. Press [\*] to continue.

Program Alpha?  
0 = No 1 = Yes 0

The next request is to enter Alpha descriptors for the zones. The entry may be done now (enter 1) or may be done at a later time using \*82 interactive mode (enter 0). We recommend that the entry of Alpha descriptors be done using \*82 mode.

See Section 10: ALPHA DESCRIPTION PROGRAMMING for specific procedure.

Enter Zn Num.  
(00 = Quit) 02

If "0" (no) was entered above, the system will return to the "Enter Zone Number" prompt. Proceed with the programming for the next zone, as indicated previously.

Enter next zone number ↑

When you have finished programmed the hard-wired zones, exit \*56 interactive mode at the "Enter Zone Number" prompt by pressing: [0] [0].

Then exit the programming mode by pressing \*99.

**Check-Out Procedure For Hard-Wired Zones**

After installation of all hard-wired devices is completed, the security system should be checked, as follows.

1. Make certain that all devices and sensors connected to the hard-wired zones are not in a faulted state. Doors and windows with contacts should be closed, PIRs should be covered (use a cloth to mask them temporarily if necessary).
2. Power up the system temporarily.
3. After a 50 second delay, with all hard-wired zones intact, the Alpha keypad connected to the system should display:

**(If Burglary features are enabled)**

**(If Burglary features are disabled)**

DISARMED  
READY TO ARM.

SYSTEM  
NORMAL

If the following is displayed,

DISARMED Press \*  
to show faults

PRESS \* TO SHOW  
FAULTS

press the [\*] key to display the faulted zone(s). Restore any faulted zone(s) as necessary (also make sure that you have connected a 2K-ohm EOL resistor across the terminals of unused zones).

When the DISARMED...READY TO ARM message or SYSTEM NORMAL is displayed, you can proceed to the next step.

4. Fault and then restore every contact or sensor on each zone individually to ensure that it is being monitored by the system. Each time a burglary zone is faulted, the keypad should display the number of the faulted zone. When each burglary zone is restored, the READY TO ARM or SYSTEM NORMAL message should appear again. For fire and 24-hr. zones, this test may activate external alarm sounders and send a central station report. Therefore, alert building occupants and the central station before conducting this test.
5. When you get the proper displays on the keypad(s), the hard-wired zones in the system are functioning properly.

## Section 6. SYSTEM ZONES

This section provides the following information:

- General information about system zones
- System zone assignments

### General Information

System zones may be comprised of the following:

- Zones which monitor various device connections, as well as earth ground faults
- Keypad panic zones, which may be assigned 24-hr. zone responses that are activated whether the system is armed or disarmed
- Zones which have a special purpose such as to bypass a relay, or to assign a zone descriptor to a relay

### System Zone Assignments

- Zone 6: Bell Supervision – monitors the bell circuit output for open and short circuit faults. Defaults to zone response type 19 (24-Hr. Trouble) .
- Zone 7: Keypad Panic – activated by pressing the keypad [B] key or by simultaneously pressing the[\*] and [#] keys. Keys must be held for two seconds.
- Zone 8: Keypad Duress – activated by using the duress code (corresponds to User Code # 8) at the keypad. This generates a call to the central monitoring station (only useful if a report code is programmed for Zone 8).
- Zone 10: Earth Ground Supervision – monitors the control's field wiring for earth ground faults. Defaults to zone response type 19 (24-Hr. Trouble). Supervision must be enabled (response type 19) for fire installations.
- Zone 11: Main Dialer Supervision – monitors the main dialer telephone connection for line faults. Defaults to zone response type 19 (24-Hr. Trouble).
- Zone 12: Back-up Dialer Supervision – monitors the backup dialer telephone connection for line faults. Defaults to zone response type 19 (24-Hr. Trouble).
- Zone 13: Auxiliary Relay Disable – represents the auxiliary relay for purposes of allowing this relay to be bypassed. Does not supervise anything and does not get assigned a zone response type.
- Zone 95: Keypad Panic – activated by pressing the keypad [A] key or by simultaneously pressing the [1] and [\*] keys. Keys must be held for two seconds.
- Zone 96: Keypad Panic – activated by pressing the keypad [C] or by simultaneously pressing the [3] and [#] keys. The keys must be held for two seconds to activate the panics.

System zones are programmed through \*56 Zone Programming Mode.

The default values for these zones will meet the requirements for most installations.



# Section 7. ALARM INDICATING DEVICES

This section provides the following information:

- General information about the bell circuit output
- Connecting alarm indicating devices
- Examples of compatible alarm indicating devices
- Using the PS24 Power Supply Module
- Programming external sounder options

## General Information

The Ademco 5120XM provides one 12VDC bell circuit output (rated at 10-14VDC), which must be connected to the PS24 Power Supply module for powering 24V alarm indicating devices (horns, bells, sirens, etc.). This output may be configured for Style Y EOLR supervision or no supervision, and is intended for use as a supervised fire alarm indicating circuit.

Alarm indicating devices for burglary alarm sounding should be connected to the auxiliary relay output, as described in the next section.



The total alarm current that can be drawn from 5120XM's bell, auxiliary relay, auxiliary power output #1, and auxiliary power output #2 outputs combined must not exceed 1 amp.

The PS24 Power Supply Module provides an additional 1.7A @24VFW (full wave rectified, unfiltered) current.

## Connecting Alarm Indicating Devices



Mount the PS24 module in the 5120XM cabinet as per instructions supplied with the PS24.

Make connections from alarm output terminals on the control (Terminals 3 and 4) to PS24 Input A Terminals 10(+) and 11(-), or Input B Terminals 15(+) and 16(-). If Input A is used, Output A must be used to connect alarm indicating devices; if Input B is used, Output B must be used to connect alarm indicating devices.

Wire polarized alarm indicating devices to the PS24 Output as shown below.

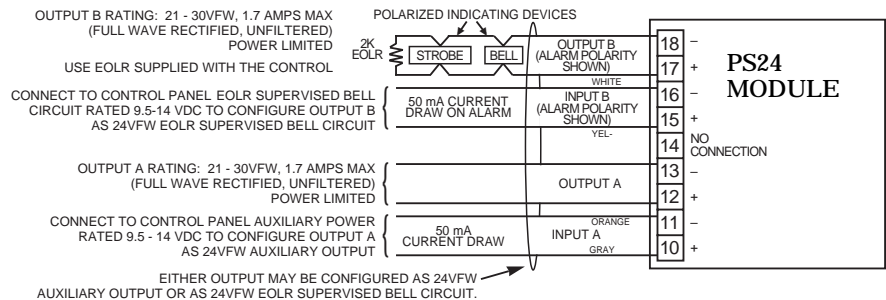

**Figure 6: Making Bell Circuit Connections Using Input and Output B of the PS24 Power Supply Module .**

To supervise the bell output wiring, do the following:

- Connect polarized 24V alarm indicating devices in parallel across either Output A or B (depending on which Input is used) of the PS24 Power Supply Module.
- Attach a 2K-ohm EOLR (Model #610-7, supplied) across the bell wires at the last device on the wire run.
- Program Zone 6 for a 24-Hr. trouble response type (this is the default).



In fire installations, the bell output must be configured for EOLR supervision.

To unsupervise the bell output wiring, do the following:

- Cut the white jumper labeled W2 on the control panel.
- Program Zone 6 for a response type of "0" (not used).



The PS24's Low AC and Low Battery outputs must be connected to the 5120XM's Connector J5 pins 8 and 9, respectively, and **not** to supervised zones on the 5120XM, as shown in the PS24's Installation Instructions. Additionally, program field \*37 must be set to "1" so that the 5120XM will read AC and battery power status from the PS24's Low AC and Low Battery outputs instead of from its internal AC/battery monitoring circuitry.

### Compatible Alarm Indicating Devices

Use only polarized 21-30VFW, UL listed alarm indicating devices. The following are examples of compatible devices.

#### Horn/Strobes:

System Sensor	MASS2415ADA
System Sensor	MASS2475ADA
System Sensor	MASS24110ADA
System Sensor	MASS241575ADA
Wheelock	MT-24-LS-VFR & MT4-24-LS-VFR
Wheelock	MT-24-LSM-VFR & MT4-24-LSM-VFR
Wheelock	MT-24-MS-VFR & MT4-24-MS-VFR
Wheelock	MT-24-IS-VFR & MT4-24-IS-VFR
Gentex	SHG24-15-1
Gentex	SHG24-1575
Gentex	SHG24-110-1

#### Strobes:

System Sensor	SS2415ADA
System Sensor	SS241575ADA
System Sensor	SS2475ADA
System Sensor	SS24110ADA
Wheelock	LS1M-24-VFR
Wheelock	MS1-24-VFR
Gentex	GXS-4-15-1
Gentex	GXS-4-1575
Gentex	GXS-4-110-1

### BELL CIRCUIT WIRE RUN LENGTH TABLE

NOTE: Lengths below are measured from PS24 to farthest device on wire run. These lengths correspond to a voltage drop of 2.4V

Bell Current (mA)	#18 AWG	#16 AWG	#14 AWG	#12 AWG
100	1870 ft	2980 ft	4750 ft	7550 ft
250	750 ft	1190 ft	1900 ft	3020 ft
500	375 ft	590 ft	950 ft	1510 ft
750	250 ft	390 ft	630 ft	1000 ft
1000	180 ft	290 ft	470 ft	750 ft
1250	150 ft	230 ft	380 ft	600 ft
1500	120 ft	190 ft	310 ft	500 ft
1700	110 ft	170 ft	270 ft	440 ft

#### Programming External Sounder Options

1. With at least one 2-line Alpha keypad (6139/6139R)) connected to the keypad terminals on the control, power up the system temporarily.
2. Enter the programming mode by keying the following on the Alpha keypad: **Master code (5 1 2 0) + 8 0.**
3. **Press \*30. (Alarm Bell Timeout).**  
Enter 0 for no timeout (default), 1 for 4 min, 2 for 8 min, 3 for 12 min, or 4 for 16 min. Fire bells must be programmed to sound for at least 5 minutes.
4. **Press \*28. (Single Alarm Sounding per Zone/Armed Period).**  
Enter "1" for yes, "0" for no (default).
5. **Press \*76. (Waterflow Alarm Silencing).**  
Enter "0" for manual silence only (default), "1" for automatic silence when waterflow ceases.  
  
The automatic silence option may only be used with the permission of the local AHJ.
6. **Press \* 77. (Alarm Bell Sound).**  
Enter "0" for pulsing (default), "1" for steady.



The pulsing option causes the bell to sound using the NFPA three pulse temporal pattern.

7. **Press \*85. (Bell and Aux. Relay Activation for Zones 1-7).**  
Enter Relay/Bell assignments for each zone as follows:  
0 = No output; 1 = Bell; 2 = Aux. Relay; 3 = Bell & Aux relay
8. **Press \*86. (Bell and Aux. Relay Activation for Zones 10-12, 95 & 96)**  
0 = No output; 1 = Bell; 2 = Aux. Relay; 3 = Bell & Aux relay



Zones programmed for fire alarm response (zone types 9, 16, and 17) must be assigned to trigger the bell output (can trigger the aux. relay additionally). Therefore, option 1 or 3 must be selected for fire zones.

#### 9. Press \*56. (Zone Programming mode).

Program Zone 6 for 24-Hr. trouble response to supervise the bell output, or "0" to disable bell supervision (default is zone type 19 – 24-Hr. Trouble).

# Section 8: AUXILIARY RELAY CONNECTIONS

This section provides the following information:

- General information about the auxiliary relay
- Wiring the auxiliary relay
- Programming the auxiliary relay

## General Information

The 5120XM provides on auxiliary relay output which may be configured as one of the following:

- Wet 12VDC form C relay output
- Dry, unsupervised form C relay output with contacts rated at 30VAC/VDC, 2A max, resistive loads.

The relay pole (terminal 6) is set at the factory for a 12V nominal (10-14VDC) output, providing 400mA max standby current/1A max alarm current.

The total combined standby current that can be drawn from the 5120XM's auxiliary relay, aux. power #1, and aux. power #2 outputs cannot exceed 400mA. The total alarm current that can be drawn from these outputs plus the bell output cannot exceed 1A.

If configuring the relay as a dry, form C relay output, cut the red jumper labeled W3 on the PC board.

Installations providing burglary alarm service should use this output for burglary alarm bell activation (configure as a 12V output, which activates on burglary alarm and provides arming ding).

## Relay Connections

The figures below show how to wire the auxiliary relay output for burglary alarm output and for 4-wire smoke detector power usage.

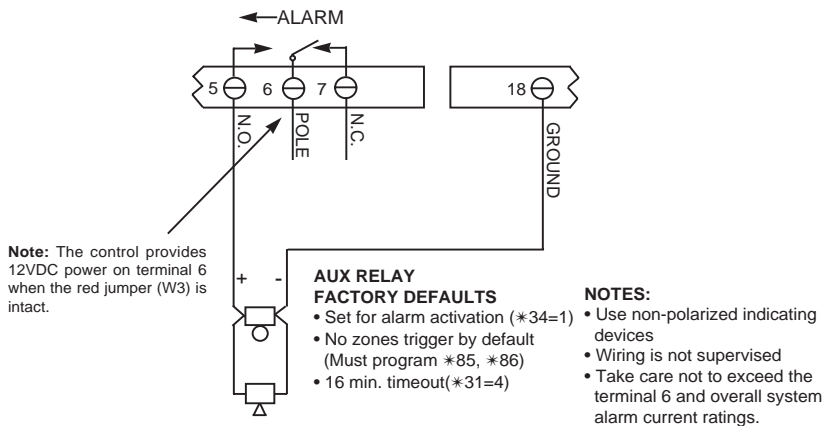

**Figure 7: Wiring the auxiliary relay output for burglary alarm output.**

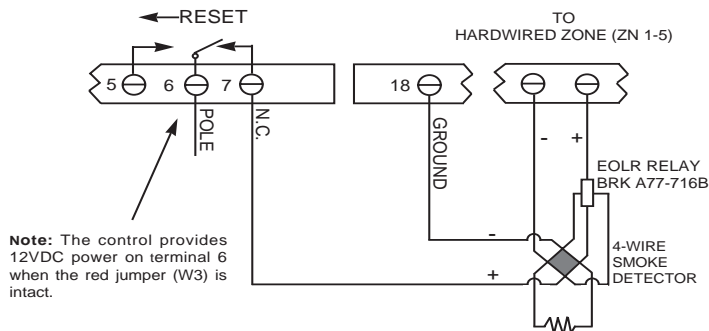

**Figure 8: Wiring the auxiliary relay output for 4-wire smoke detector power usage.**

## Programming the Auxiliary Relay

The auxiliary relay may be programmed for one of the following options:

- Trouble/Supervisory Activation
- Alarm Activation, silenced by [User Code] + OFF
- 4-Wire Smoke Detector Reset
- Battery Saver
- Alarm Activation, silenced by [User Code] + # 67

These options are described below:

- **Trouble/Supervisory Activation (\*34 = 0)** : Steady activation in response to any zone or system related trouble condition or to any fire supervisory condition. Remains activated until all fault conditions have been corrected and the User Code + OFF has been entered.
- **Alarm Activation, silenced by [User Code] + OFF (\*34 = 1)**: Steady activation in response to an alarm on one, some or all zones, as selected in fields \*85 and \*86. If selected, the auxiliary relay remains activated until Aux. Relay Timeout (\*31) or until the User Code + OFF has been entered.  
When field \*34 = 1, the auxiliary relay can also be programmed to give a brief activation for confirmation of arming (field {\*35}).

- **4-Wire Smoke Detector Reset (\*34 = 2)**: Momentary (6 second) activation at second entry of User Code + OFF sequence which interrupts power to 4-wire smoke detectors connected to hard-wired zones (zones 1-5), allowing the detectors to be reset following an alarm . Power to 4-wire smoke detectors should be wired to the auxiliary relay as shown in Figure 8.

- **Battery Saver Option (\*34 = 3)**: When this function is selected, the auxiliary relay will normally be activated (i.e. N.O. and pole contacts will be connected, N.C. contact will be open) and will de-activate 4 hours after the start of an AC power failure. Using this feature, non-critical loads (such as supplementary keypads) which do not need to be supported for the full 24 hour battery backup period can be disconnected from the auxiliary outputs, allowing a smaller capacity battery to be used. The relay re-activates within a few seconds after AC power restores.

- **Alarm Activation, silenced by [User Code] + # 67 (\*34 = 4)**: Steady activation in response to an alarm on one, some or all zones, as selected in fields \*85 and \*86. If selected, the auxiliary relay remains activated until the User Code + #67 has been entered.

When this function is used, the auxiliary relay can be used for elevator recall or ventilator shutdown on fire alarms.

## Section 9. FINAL POWER UP

This section provides the following information:

- Connecting the AC transformer
- Making earth ground connections
- Applying power to the control
- Installing the backup battery
- Backup battery calculations

In Section 2, you made temporary power connections for the purpose of programming and testing the installation. This section provides information about final power-up procedures and battery size calculations.

### AC Power Connections

The 5120XM has a built-in, enclosed AC power transformer with manually resettable circuit breaker protection, located in the lower lefthand corner of the control's cabinet.

**UL**

1. A dedicated 120VAC circuit must be used for fire applications. Run 120VAC wiring to the control in conduit.
2. Wires must be rated for 90 degrees -C or higher operation.

Follow the steps below to make AC power connections.

1. Remove the cover from the transformer's enclosure.
2. Remove the lower knockout on the lefthand side of the cabinet. Run 120VAC power wires into the transformer enclosure via this knockout.



***Make sure that the dedicated AC circuit is not powered at this time.*** Apply AC power only after all other wiring, except the backup battery wiring, has been completed.

3. Use wire nuts (not supplied) to splice the 120VAC wires to the transformer's black and white flying leads. Push the mated wires back into the transformer enclosure.
4. Connect the transformer's 18VAC BLUE flying leads which emerge from the top of the enclosure to the 5120XM's AC terminals (Terminals 1 and 2). Connect the transformer's 30VAC Yellow flying leads that emerge from the top of the enclosure to the PS24's AC terminals (Terminals 1 and 2).

Maintain at least 1/4" spacing between the transformer's blue and yellow wires and other control field wiring. The yellow wires should be tie-wrapped to the tie-wrap loop on the cabinet's left side wall when the PS24 will not be used.

5. Connect pin 8 on the J5 header of the 5120XM to Terminal 8 on the PS24 Power Supply for AC power supervision.
6. Make earth ground connections as specified below.

### Earth Ground Connections



The 5120XM requires connection to a good earth ground in order to provide proper 120VAC shock hazard protection, lightning transient protection, and earth ground fault detection.

Refer to the National Electrical Code for proper earth grounding methods.

To make earth ground connections, do the following:

1. Run an earth ground wire into the transformer enclosure via the same knockout used for 120VAC wiring.
2. Use a wire nut (not supplied) to splice this earth ground wire to the green flying lead located inside of and bonded to the transformer enclosure. Push the mated wires into the enclosure.

3. Connect the green flying lead which emerges from the top of the transformer enclosure to the 5120XM's earth ground terminal (Terminal 8). Make a connection between this terminal and the PS24's earth ground terminal (Terminal 3).
4. Replace the transformer enclosure cover after wiring is complete.

### Powering Up the System

Apply AC power to the control. Following power-up, **Busy-Standby** (Alpha keypads) or **NOT READY** (fixed-word keypads) will be displayed.

After approximately 1 minute, the initial displays will revert to **DISARMED...READY TO ARM** or **SYSTEM NORMAL** for Alpha keypads, or **AC** for Fixed-word keypads (if there are no faulted zones). This 1-minute delay allows PIRs, etc. to stabilize.

**To bypass this delay, press: [#] + [0].**

### Connecting The Back-Up Battery

In the event of an AC power loss, the 5120XM control and PS24 power supply module must be supported by a back-up, rechargeable, lead acid (gel cell type) battery. Two 12V, 7AH min/17.2AH max. batteries must be connected to the PS24. The PS24 configures these batteries to provide 24V backup power to its outputs, and 12V backup power to the 5120XM control and its outputs.

The battery's capacity must be sized to provide 24 hours (UL Central Station Fire) or 60 hours (UL Remote Station Fire) of standby time followed by 5 minutes (UL Local Fire only) or 15 minutes (UL Local Fire/Burglary) of alarm time. Use the steps below to calculate the required battery capacity.



Only two 12V, 7AH or 12V, 12AH batteries will fit in the 5120XM's cabinet.

### Calculating the Battery Size Needed

Use the worksheets below to determine the total standby and alarm loads, and the required battery capacity. Then select two batteries having a capacity greater than or equal to the calculated capacity.

## TOTAL STANDBY/ALARM LOAD WORKSHEETS

To calculate the total current for the 5120XM's Aux. power 1, Aux power 2, bell & aux. relay outputs, multiply each device's standby and/or alarm current by the number of units used.

- 1) Enter devices used on aux. power 1 output, calculate standby and alarm currents, then add to get aux. power 1 current subtotal.

AUX. POWER 1 OUTPUT				Total Current		
Device Model #	Device Current	X	# of Units	=	Standby	Alarm
<b>Aux. Power 1 Output Subtotal</b> (terminals 17 & 18)					400mA max	400mA max

Note: 6137/6137R Draws 85mA during alarm and 40mA during battery standby  
6139/6139R Draws 100mA during alarm and 40mA during battery standby

- 2) Enter devices used on aux. power 2 output, calculate standby and alarm currents, then add to get aux. power 2 current subtotal.

AUX. POWER 2 OUTPUT				Total Current		
Device Model #	Device Current	X	# of Units	=	Standby	Alarm
<b>Aux. Power 2 Output Subtotal</b> (connector J5-pins 5,1)					400mA max	400mA max

- 3) Enter devices connected to bell output, calculate alarm currents, then add to get bell output current subtotal.

BELL OUTPUT				Total Current		
Device Model #	Device Current	X	# of Units	=	Standby	Alarm
PS24 PWR. SUP.	50mA		1		XXXXXX	50mA
Bell Output Subtotal					XXXXXX	50mA

- 4) Enter devices connected to the aux. relay output, calculate standby and alarm currents, then add to get aux. relay output current subtotal.

AUX. RELAY OUTPUT				Total Current		
Device Model #	Device Current	X	# of Units	=	Standby	Alarm
<b>Aux. Relay Output Subtotal</b> (terminals 5, 6, 7 & 18)					(400 mA max)	(1.0 amp max)

Note: No entries are necessary when red relay power jumper W3 is cut.



- 5) Enter the calculated subtotals of all listed outputs then add to get combined current.

<b>COMBINED AUX. POWER, AND BELL</b>	Total Current	
	Standby	Alarm
Aux. Power 1 Output Subtotal		
Aux. Power 2 Output Subtotal		
Bell Output Subtotal	XXXXXX	
Aux. Relay Output Subtotal		
Add all subtotals (Cannot exceed 400mA max. standby; 1.0 amp max. alarm)		

- 6) Enter the calculated combined currents then add to total PCB current.

<b>TOTAL 5120XM LOAD @ 12V</b>	Total Current	
	Standby	Alarm
Combined aux. power, and bell total		
Total 5120XM PCB current	132 mA	214mA
Total 5120XM load*		

	*Limit the total 5120XM load (standby) to 212mA when a 60 hour standby time is desired.
---	---

- 7) Enter the total 5120XM load and convert to equivalent 24V load.

<b>Total 5120XM Load</b>	<b>Standby</b>	<b>Alarm</b>
Total 5120XM load at 12V (from above worksheets)		
Equivalent 5120XM load at 24V (multiply above values by 0.62)		

- 8) Enter devices connected to the PS24 Output A,, calculate alarm currents, then add to get PS24 Output A current subtotal.

<b>OUTPUT A Device Model #</b>	<b>Device Current</b>	<b>X # of Units =</b>	<b>Total Current</b>	
			<b>Standby</b>	<b>Alarm</b>
Total OUTPUT A load (total for all devices on OUTPUT A)			(570 mA max)	(1.7A max)

- 9) Enter devices connected to the PS24 Output B,, calculate alarm currents, then add to get PS24 Output B current subtotal.

OUTPUT B Device Model #	Device Current	X # of Units	=	Total Current	
				Standby	Alarm
Total OUTPUT B load (total for all devices on OUTPUT B)				(570 mA max)	(1.7A max)

- 10) Enter the calculated combined currents and then add PS24 PCB current and Equivalent 5120XM Load from step 7 to get total PS24 module load.

TOTAL PS24 MODULE LOAD	Standby	Alarm
Total OUTPUT A load (total for all devices on OUTPUT A)	(570 mA max)	(1.7A max)
Total OUTPUT B load (total for all devices on OUTPUT B)	(570 mA max)	(1.7A max)
5120XM LOAD @24V (equivalent control panel load at 24V as calculated above)		
PS24 PCB current (these values are fixed)	40 mA	40 mA
Total PS24 module load (add currents in columns above)	(610 mA max)	(4.18A max)

- 11) Using the total calculated PS24 module load (step 10), calculate the battery capacity required for the installation.

**BATTERY CAPACITY CALCULATION WORKSHEET**

Capacity	Formula	Calculated Value
Standby Capacity	Total standby load x 24 (or 60) hours x 1.1 contingency factor (use total PS24 standby load)	
Alarm Capacity	Total alarm load x alarm time in hours i.e.: 5 minutes = 0.083 hours 15 minutes = 0.250 hours (use total PS24 alarm load)	
Total Capacity	Add standby and alarm capacities	

- 12) Using the battery capacity from step 11, select the appropriate battery.

**BATTERY SELECTION TABLE**

Amp Hours	Yuasa Model Number	Comments
7 AH	NP7-12	2 required
12 AH	NP12-12	2 required
17.2 AH	NPG18-12	2 required



Use two batteries from the same manufacturer, with the same capacity and approximately the same age. Replace both batteries at the same time even if only one battery is low.

### **Making the Battery Connections**

1. Use the battery capacity calculation worksheet (above) to determine the appropriate battery for the installation.



Do not connect the batteries until all devices have been wired to the control.

2. Verify that the proper float charging voltage (27.0–27.6VDC) is present across the BATT 1 (+) (Terminal 4) and Batt 2 (-) (Terminal 7) of the PS24 before connecting the battery. If not, check that the the blue 18VAC transformer wires are connected to the 5120XM (terminals 1 &2) and that the 5120XM's auxiliary power and auxiliary relay outputs are not loaded in excess of their ratings.
3. Connect the battery tabs on the control board to the battery tabs on the PS24 Power Supply board using the cables supplied with the 5120XM; +) to (+), (-) to (-), respectively.  
(See the SUMMARY OF CONNECTIONS diagram for location of the (+) and (-) battery tabs on the control board.)
4. Both batteries should be mounted as shown in the figure below to ensure that neither battery's terminals can be shorted.

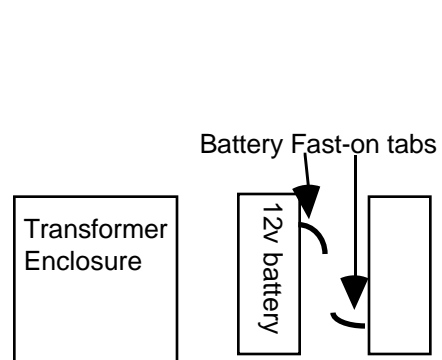

5. Connect a 12V, 7AH min./17.2AH max battery to PS24 Terminals 4 and 5 as follows: (+) side to Terminal 4, (-) side to Terminal 5.  
Connect another 12V, 7AH min./17.2AH max battery to PS24 Terminals 6 and 7 as follows: (+) side to Terminal 6, (-) side to Terminal 7.



The PS24 internally connects these two batteries in series for 24V bell operation, and supplies 12V to the control for back-up.

6. Connect pin 9 on the 5120XM J5 header to Terminal 9 on the PS24 Power Supply for low battery supervision.

### **Battery Supervision**

The PS24 runs a brief battery test every minute to determine if battery leads are connected and runs an extended battery test every 17 hours to determine if battery capacity is low (less than approximately 23.0V). If a low battery condition exists, it will be displayed at the control's keypad(s).

# Section 10.

## ALPHA DESCRIPTOR PROGRAMMING

This section provides instructions for programming Alpha descriptors, which is recommended for systems using Alpha keypads.

The ALPHA VOCABULARY LIST and CHARACTER CHART are found later in this section.

### Assigning Zone Descriptors

The Alpha Keypad used with the 5120XM can have a user-friendly English language description/location of all protection zones and keypad panics programmed into the system. Each description can be composed of a combination of words (up to a maximum of 3) selected from a vocabulary of 249 words stored in memory (listed later in this section). In addition, up to 5 installer-defined words can be added to those already in memory. Thus, when an alarm or trouble occurs in a zone, an appropriate description for that zone's location will be displayed at the keypad.

**Note:** Alpha Descriptor entry can be done locally at the Alpha Keypad or remotely using Downloading software. The Alpha keypad procedure is described below.

### Entering Zone Descriptors (program menu mode \*82)

The descriptor can be entered when the zone is being defined in field \*56 but we recommend that it be done in field \*82.

There are two methods that can be used to enter Alpha descriptors.

The easiest method requires that you simply enter the 3-digit reference number for the desired word(s). The 3-digit number for each word is provided in the Alpha Vocabulary list (on a following page).

An alternate method allows you to pick the desired words by scrolling through the Alpha Vocabulary list.

### Programming the Descriptors

1. With the system powered up, enter the programming mode by keying: **Master code (5 1 2 0) + 8 + 0**. The following display will appear:

Master Code	20
-------------	----

Program Alpha ?	00
0 = No, 1 = Yes	

Custom Words ?	00
0 = No, 1 = Yes	

2. **Press \*82.**  
The "Program Alpha ?" prompt will appear.
3. **Press "1" (Yes).**  
The "Custom Words" prompt will appear.

*Summary Mode Display*

Default Descriptor ↓

\* ZN 01 ZONE 01

Flashing Cursor (system is ready for entry of word).  
↓

\* ZN 01 A

Flashing Cursor ↓

\* ZN 01 B ACK

\* ZN 01 BACK  
A

↑  
Flashing Cursor if "6" is pressed (system is ready for next word).

\* ZN 01 BACK  
D OOR

↑Flashing Cursor

4. **Press "0" (No).**\* The system will then automatically display the descriptor for zone 1.

\* The procedure for adding custom words to the built-in vocabulary will be found later under "Adding Custom Words".

If a descriptor was not entered previously for zone 1, the default descriptor for zone 1 will be displayed.

Note that this a "summary mode", and that no entries can be made. Entries can be made only when the display contains a flashing cursor, which signifies the "entry mode".

5. To delete or change the default descriptor for zone 1, **press \* plus the same zone number (01)**. This will clear that descriptor and gain access to the entry mode with flashing cursor, allowing changes to be made.

NOTE: If you do not wish to change the existing descriptor for zone 1, enter \* plus the next zone number for which you wish to enter (or check) a descriptor. A summary display for that zone will appear. You must then press \* plus the same zone number again to gain access to the entry mode (flashing cursor) for that zone.

6. **Press # plus 3-digit number** for the first word from the "Alpha Vocabulary List". Example: The descriptor that we wish to enter for zone 1 is BACK DOOR. From the list, BACK = 015. Therefore, you would enter # **0 1 5**.

**Note:** If you accidentally enter the wrong word, simply press # plus the correct 3-digit number for the word you want.

7. **Press "6" to accept the selected word and continue.**

**Note:** If this is the only word you are using for the descriptor, press "8" instead of "6" to save that word in memory, and then go to step 11.

8. **Enter the 3-digit number for the next word.** In our example, the word is DOOR, whose number is "061".

Enter # **0 6 1**. This display will appear:

```

* ZN 01  BACK
DOOR  A

```

↑  
Flashing Cursor if "6" is pressed (system ready for next word).

Summary Display

```

* ZN 01  BACK
DOOR

```

```

Program Alpha ?
0 = No, 1 = Yes  00

```

```

Alpha Pgm
82

```

9. Press "6" to accept the selected word.

**Note:** If these are the only words you are using for the descriptor, press "8" instead of "6" to save them in memory.

10. The two words in our example have now been entered. Note, however, that up to three words may be entered (provided the number of characters will fit on the screen). Press "8" to save all words in memory.

The "A" with the flashing cursor over it will disappear, indicating that the word(s) are stored in memory for that zone, as shown in the summary display at the left.

11. To enter a descriptor for the next zone, press \* plus the desired zone number (e.g., \*02. The summary display following step 4 previously will appear. Now repeat steps 5 through 10 for the descriptor for the next zone.

12. To exit the Alpha descriptor mode, press "\*+0+0" at the summary display.

This prompt will be displayed.

13. Press "0". This will be displayed.

14. Press \*99 to exit the programming mode.

**Alternate Method For Programming Zone Descriptors**

1. Perform steps 1 through 5 of previous method.
2. Note that the first letter of the alphabet appears after the zone number, and that the zone number is automatically included with the description. *If there already is a description for the zone, the description will appear (with no cursor, since this is a display mode). To enter or change a description, press [\*] + Zone Number again. A flashing cursor will now appear.* Assume, for example, that the desired description for zone 1 is BACK DOOR.
3. **Select the first letter of the desired description** (note that "A" is already displayed). Press key [3] repeatedly to advance through the alphabet (e.g., to "B"), or key [1] to go backward. Then press [6] to display the first available word beginning with the desired letter (e.g., BABY). Next, press [3] repeatedly to move forward, or [1] to move backward, until the desired word is displayed (e.g., BACK). Then press [6] to accept the word and toggle back to the alphabet list.

**When entering Zone Descriptors using Method 2, the keypad keys perform the following functions:**

- [3] Scrolls both alphabet and actual words in ascending alphabetical order.
- [1] Scrolls both alphabet and actual words in descending alphabetical order.
- [6] Selects between alphabet and actual word list; also used to save words.
- [8] Stores the zone description in memory.

4. For selection of the next word (e.g., DOOR), repeat step 3, as follows.  
Press key [3] until the first letter of the next word appears (e.g., "D"). Then press [6] to display the first available word beginning with that letter (e.g. DAUGHTERS). Press [3] repeatedly until the desired word (e.g., DOOR) appears. To accept the word, press [6], which toggles back to the alphabet list.
5. When all desired words have been entered, press [8] to store the description in memory.
6. Enter \*NN, where NN is the next zone that you want to review or for which you want to program a descriptor. To modify the descriptor, enter \*NN again. To exit this mode, press "\*00".

### Adding Custom Words

You can add up to five installer-defined words to the built-in vocabulary. Each of the five "words" can actually consist of a "word string" of one or more words, but no more than *ten* characters can be used for each word or word string.



Custom words must begin with an *alphabetic* character. If a number or symbol is used as the first character, the word will not be saved.

**When adding Custom Words in steps 3–6, the keypad keys perform the following functions:**

- [3] Advances through the alphabet in ascending order.
- [1] Moves through the alphabet in descending order.
- [6] Selects desired letter; moves cursor one space to right.
- [4] Moves cursor one space to left.
- [7] Inserts a space at the cursor location, erasing any character located there.
- [8] Saves the new word in the system's memory.

1. Perform steps 1, 2, and 3 of **Programming the Descriptors** on a previous page.  
Select CUSTOM WORD mode (enter "1") when the prompt **CUSTOM WORD ?** is displayed.
2. Enter the number ([1]–[5]) of the custom word or word string to be created (for example, if you are creating the *first* custom word or word-string, enter [1], for the *second*, enter [2], etc.). A cursor will now appear at the beginning of the second line.
3. **One of two methods of entering the custom word's characters can now be used** (refer to the *CHARACTER LIST* of letters, numbers, and symbols on a following page):
  - Method 1:**  
Press the [#] key, followed by the two-digit entry for the first letter you would like to display (e.g., [6][5] for "A"), **or...**
  - Method 2:**  
Use the [3] key to advance through the list of symbols, numbers, and letters. Use the [1] key to move back through the list.
4. When you have reached the desired character, press [6] to select it. The cursor will then move to the right, in position for the next character.
5. Repeat steps 3 and 4 to create the desired word(s). Note that the [4] key can be used to move the cursor to the left, if necessary, and that key [7] can be used to enter a blank (or erase an existing character). Remember, no word or word-string can exceed 10 characters.
6. Press the [8] key to save the custom word(s) and return to the "**CUSTOM WORD ?**" display.  
Repeat steps 2–5 for other custom words to be entered. To change a custom word, just overwrite it. If no more are to be entered now, press [0] to return to the Descriptor entry. The custom word(s) will be automatically added to the built-in vocabulary.

When zone descriptors are being entered as described in step 6 of **Programming the Descriptors**, the custom word numbers are 250 to 254 for words 1 to 5 respectively.

When being entered as described in step 3 in **Alternate Method For Programming Zone Descriptors**, each word will be found at the end of the group of words that begin with the same letter as it does.

# ALPHA VOCABULARY LIST

(For Entering Zone Descriptors)

000	(Word Space)								
	<b>A</b>	058	<b>K</b>		<b>R</b>		<b>V</b>		
001	AIR	059	111	KITCHEN	161	RADIO	214	VALVE	
002	ALARM	060		<b>L</b>	162	REAR	215	VAULT	
003	ALCOVE	061	112	LAUNDRY	163	RECREATION	216	VIBRATION	
004	ALLEY	062	113	LEFT	164	REFRIG	217	VOLTAGE	
005	AMBUSH	063	114	LEVEL	165			<b>W</b>	
006	ANTENNA	064	115	LIBRARY		REFRIGERATION	218	WALL	
007	AREA	065	116	LIGHT	166	RELAY	219	WAREHOUSE	
008	APARTMENT	066	117	LINE	167	RF	220	WASH	
009	ART	067	118	LIQUOR	168	RIGHT	221	WEST	
010	ATTIC	068	119	LIVING	169	ROOM	222	WINDOW	
011	AUDIO		120	LOADING	170	ROOF	223	WINE	
012	AUX		121	LOCK			224	WING	
013	AUXILIARY	069	122	LOOP	171	SAFE	225	WIRELESS	
	<b>B</b>	070	123	LORRA	172	SCREEN	226	WORK	
014	BABY	071	124	LOW	173	SENSOR		<b>X</b>	
015	BACK	072	125	LOWER	174	SERVICE	227	XMITTER	
016	BACKUP	072		<b>M</b>	175	SHED		<b>Y</b>	
017	BAR	074	126	MACHINE	176	SHOCK	228	YARD	
018	BARN	075	127	MAGNETIC	177	SHOP		<b>Z</b>	
019	BASEMENT	076	128	MAIDS	178	SHORT		229	ZONE (No.)
020	BATHROOM	077	129	MAIN	179	SHOW	230	ZONE	
021	BED		130	MASTER	180	SIDE			
022	BEDROOM	078	131	MAT	181	SKYLIGHT			
023	BELL	079	132	MEDICAL	182	SLIDING	231	0	
024	BLOWER	080	133	MEDICINE	183	SMOKE	232	1	
025	BOILER	081	134	MICROWAVE	184	SONIC	233	1ST	
026	BOTTOM	082	135	MONEY	185	SONS	234	2	
027	BOX	083	136	MONITOR	186	SOUTH	235	2ND	
028	BREAK	084	137	MOTHERS	187	SPRINKLER	236	3	
029	BUILDING	085	138	MOTION	188	STATION	237	3RD	
030	BURNER	086	139	MOTOR	189	STEREO	238	4	
	<b>C</b>	087		<b>N</b>	190	STORE	239	4TH	
031	CABINET	088	140	NORTH	191	STORAGE	240	5	
032	CALL	089	141	NURSERY	192	STORY	241	5TH	
033	CAMERA	090		<b>O</b>	193	STRIKE	242	6	
034	CAR	091	142	OFFICE	194	SUMP	243	6TH	
035	CASE	092	143	OIL	195	SUPERVISED	244	7	
036	CASH		144	OPEN	196	SUPERVISION	245	7TH	
037	CCTV	093	145	OPENING	197	SWIMMING	246	8	
038	CEILING	094	146	OUTSIDE	198	SWITCH	247	8TH	
039	CELLAR	095	147	OVERFLOW			248	9	
040	CENTRAL	096	148	OVERHEAD			249	9TH	
041	CIRCUIT	097		<b>P</b>	199	TAMPER			
042	CLIP	098	149	PAINTING	200	TAPE	250	Custom Word #1	
043	CLOSED	099	150	PANIC	201	TELCO			
044	COIN	100	151	PASSIVE	202	TELEPHONE			
045	COLD		152	PATIO	203	TELLER			
046	COATROOM	101	153	PERIMETER	204	TEMPERATURE	251	Custom Word #2	
047	COLLECTION	102	154	PHONE	205	THERMOSTAT			
048	COMBUSTION	103	155	PHOTO	206	TOOL			
049	COMPUTER	104	156	POINT	207	TRANSMITTER	252	Custom Word #3	
050	CONTACT	105	157	POLICE	208	TRAP			
	<b>D</b>		158	POOL	209	TRIGGERS	253	Custom Word #4	
051	DAUGHTERS	106	159	POWER					
052	DELAYED	107		<b>Q</b>	210	UP			
053	DEN	108	160	QUAD	211	UPPER	254	Custom Word #5	
054	DESK	109			212	UPSTAIRS			
055	DETECTOR	110			213	UTILITY			
056	DIALER								
057	DINING								



# CHARACTER (ASCII) CHART

(For Adding Custom Words)

32 (space)	51 3	71 G
33 !	52 4	72 H
34 "	53 5	73 I
35 #	54 6	74 J
36 \$	55 7	75 K
37 %	56 8	76 L
38 &	57 9	77 M
39 '	58 :	78 N
40 (	59 ;	79 O
41 )	60 <	80 P
42 *	61 =	81 Q
43 +	62 >	82 R
44 ,	63 ?	83 S
45 -	64 @	84 T
46 .	65 A	85 U
47 /	66 B	86 V
48 0	67 C	87 W
49 1	68 D	88 X
	69 E	89 Y
	70 F	90 Z

# Section 11. SYSTEM COMMUNICATION

This section provides the following information:

- General information about system communication
- An explanation of report formats
- Programming communications options

## General Information

The process of a successful transmission consists of both the method of communication between the control panel and the central station receiver and the actual way the information is sent and displayed at the central station.

When the panel calls the central station receiver, it waits to hear a “handshake” frequency from the receiver to confirm that the receiver is on-line and ready to receive its message. Once the panel hears the handshake it is programmed to listen for, it sends its message. The panel then waits for a “kissoff” frequency from the receiver acknowledging that the message was received and understood.

If the handshake frequency is not given or is not understood by the panel, the panel will not send its message. Once the handshake frequency is received and understood by the panel, the panel will send its message. If there is an error in the transmission (the receiver does not receive a “valid” message), the kissoff frequency will not be given by the central station receiver.

If the secondary telephone number is programmed for backup reporting only (program field \*47 = 0), the panel will make a total of five attempts to the primary telephone number and five attempts to the secondary telephone number to get a valid message through. If only the primary number is programmed, the panel will make 10 attempts to the primary number. If the panel is not successful after its numerous attempts, the keypad will display “Communication Failure” (Alpha keypad) or “FC” (Fixed-word keypad).

The 5120XM has two dialers – a main and a back-up dialer. Each of these is enabled separately in program field \*79 (both are enabled by default). If enabled, the backup dialer will only become active when a line fault (voltage on the main dialer drops below 2 volts) is sensed. The main and back-up dialers are supervised by system zones 11 and 12, respectively.

## Report Code Formats

The following chart defines the three sets of (handshake/kissoff) frequencies that the panel supports and the different formats that can be sent for each.

FORMAT	HANDSHAKE	TRANSMITS DATA	KISSOFF	TRANSMIT TIME
Low Speed 3+1 4+1 4+2	1400Hz	1900Hz (10PPS)	1400Hz	Under 15 secs. (Standard report)
Sescoa/Rad 3+1 4+1 4+2	2300Hz	1800Hz (20PPS)	2300Hz	Under 10 secs. (Standard report)
Express 4+2	1400–2300Hz	DTMF (10 cps)	1400Hz	Under 3 secs.
Contact ID	1400–2300Hz	DTMF (10 cps)	1400Hz	Under 3 secs.

**The following describes each format in greater detail.**

<b>3+1 and 4+1 Standard Formats</b>	Comprise a 3- (or 4-) digit subscriber number and a single digit report code (e.g. Alarm, Trouble, Restore, Open, Close, etc).
<b>3+1 and 4+1 Expanded Formats</b>	Comprise a 3- (or 4-) digit subscriber account number, and a two-digit report code. The first digit is displayed on the first line, followed by a second line where the first digit is repeated 3 (or 4) times and followed by the second digit. This is the "expanded" digit.
<b>4+2 Format</b>	Comprises a 4-digit subscriber number and 2-digit report code.
<b>Ademco Contact ID Reporting Format</b>	Comprises a 4-digit subscriber number, 1-digit event qualifier ("new" or "restore"), 3-digit event code, and 3-digit zone number, user number, or system status number (see example later in this section).

<b>Report</b>	<b>3+1/4+1 Standard</b>	<b>3+1/4+1 Expanded</b>	<b>4+2</b>
Alarm	SSS(S) A	SSS(S) A AAA(A) Z	SSSS AZ
Trouble	SSS(S) T	SSS(S) T TTT(T) t	SSSS Tt
Supervisory	SSS(S) S <sub>P</sub>	SSS(S) S <sub>P</sub> S <sub>P</sub> S <sub>P</sub> S <sub>P</sub> (S <sub>P</sub> ) S <sub>P2</sub>	SSSS S <sub>P</sub> S <sub>P2</sub>
Bypass	SSS(S) B	SSS(S) B BBB(B) b	SSSS Bb
AC Loss	SSS(S) E	SSS(S) E EEE(E) A <sub>C</sub>	SSSS EA <sub>C</sub>
Low Batt	SSS(S) L	SSS(S) L LLL(L) L <sub>B</sub>	SSSS LL <sub>B</sub>
Open	SSS(S) O	SSS(S) O OOO(O) U	SSSS OU
Close	SSS(S) C	SSS(S) C CCC(C) U	SSSS CU
Cancel	SSS(S) C <sub>A</sub>	SSS(S) C C <sub>A</sub> C <sub>A</sub> C <sub>A</sub> (C <sub>A</sub> C <sub>A2</sub> )	SSSS C <sub>A</sub> C <sub>A2</sub>
Test	SSS(S) G	SSS(S) G GGG(G)g	SSSS Gg
Test (Off-normal)	SSS(S) G <sub>O</sub>	SSS(S) G <sub>O</sub> G <sub>O</sub> G <sub>O</sub> G <sub>O</sub> (G <sub>O</sub> ) G <sub>O2</sub>	SSSS G <sub>O</sub> G <sub>O2</sub>
Walk Test Start	SSS(S) W <sub>S</sub>	SSS(S) W <sub>S</sub> W <sub>S</sub> W <sub>S</sub> W <sub>S</sub> (W <sub>S</sub> ) W <sub>S</sub> ∅	SSSS W <sub>S</sub> W <sub>S</sub> ∅
Walk Test End	SSS(S) W <sub>E</sub>	SSS(S) W <sub>E</sub> W <sub>E</sub> W <sub>E</sub> W <sub>E</sub> (W <sub>E</sub> ) W <sub>E2</sub>	SSSS W <sub>E</sub> W <sub>E2</sub>
Alarm Restore	SSS(S) R	SSS(S) R RRR(R) Z	SSSS RZ
Supervisory Restore	SSS(S) R <sub>S</sub>	SSS(S) R <sub>S</sub> R <sub>S</sub> R <sub>S</sub> R <sub>S</sub> (R <sub>S</sub> ) R <sub>S</sub> ∅	SSSS R <sub>S</sub> R <sub>S</sub> ∅
AC Restore	SSS(S) R <sub>A</sub>	SSS(S) R <sub>A</sub> R <sub>A</sub> R <sub>A</sub> R <sub>A</sub> (R <sub>A</sub> )A <sub>C</sub>	SSSSR <sub>A</sub> A <sub>C</sub>
LoBat Res.	SSS(S) R <sub>L</sub>	SSS(S) R <sub>L</sub> R <sub>L</sub> R <sub>L</sub> R <sub>L</sub> (R <sub>L</sub> )L <sub>B</sub>	SSSS R <sub>L</sub> L <sub>B</sub>
Trouble Res.	SSS(S) R <sub>T</sub>	SSS(S) R <sub>T</sub> R <sub>T</sub> R <sub>T</sub> R <sub>T</sub> (R <sub>T</sub> )t	SSSS R <sub>T</sub> t
Bypass Res.	SSS(S) R <sub>B</sub>	SSS(S) R <sub>B</sub> R <sub>B</sub> R <sub>B</sub> R <sub>B</sub> (R <sub>B</sub> )b	SSSS R <sub>B</sub> b

**Where:**

SSS or	SSSS = Subscriber ID	Gg = Test Code (1st & 2nd digits)
	A = Alarm Code–1st digit	G <sub>O</sub> G <sub>O2</sub> = Off Normal Test Code (1st & 2nd digits)
	Z = Typically Zone Number*–2nd digit	W <sub>S</sub> W <sub>S2</sub> = Walk Test Start (1st & 2nd digits)
	Tt = Trouble Code (1st & 2nd digits)	W <sub>E</sub> W <sub>E2</sub> = Walk Test End (1st & 2nd digits)
SpSp2 =	Supervisory Code (1st & 2nd digits)	R = Restore Code (Alarm)
Bb =	Bypass Code (1st & 2nd digits)	R <sub>S</sub> R <sub>S2</sub> = Restore Code (Supv) 1st & 2nd digits
EA <sub>C</sub> =	AC Loss Code (1st & 2nd digits)	R <sub>T</sub> t = Restore Code (Trbl)1st & 2nd digits
LL <sub>B</sub> =	Low Battery Code(1st & 2nd digits)	R <sub>B</sub> b = Restore Code (Byp)1st & 2nd digits
	C = Close Code–1st Digit	R <sub>A</sub> A <sub>C</sub> = Restore Code (AC)1st & 2nd digits
	O = Open Code–1st Digit	R <sub>L</sub> L <sub>B</sub> = Restore Code (Bat)1st & 2nd digits
	U = User Number (in hex)	C <sub>A</sub> C <sub>A2</sub> = Cancel Code (1st & 2nd digit)

\*Zone numbers for: [\*] & [#], or [B] = 07 [1] + [\*], or [A] = 95 Duress = 92  
[3] + [#], or [C] = 96

**Ademco Contact ID Reporting** takes the following format:

CCCC Q EEE GG ZZZ

where: CCCC = Customer (subscriber) ID

Q = Event qualifier, where:

E = new event , and R = restore

EEE = Event code (3 hexadecimal digits)

**Note:** For a complete list of event codes, refer to the central office receiver manual.

GG = Always 00

ZZZ = Zone/contact ID number reporting the alarm, or user number for open/close reports. System status messages (AC Loss, Walk Test, etc.) contain zeroes in the ZZZ location.

**TABLE OF CONTACT ID EVENT CODES**

Code	Definition
110	Fire Alarm
111	Smoke/Verified Fire Alarm
113	Waterflow Alarm
121	Duress
122	Alarm, 24-hour Silent
123	Alarm, 24-hour Audible Panic
131	Alarm, Perimeter
132	Alarm, Interior
134	Alarm, Entry/Exit
135	Alarm, Day/Night
150	Alarm, 24 Hour Auxiliary
200	Fire Supervisory
301	AC Power Loss
302	Low System Battery
310	Ground Fault
321	Bell Trouble

Code	Definition
351	Main Dialer Trouble
352	Backup Dialer Trouble
353	Long Range Radio Trouble
373	Fire Loop Trouble
374	Exit Alarm
406	Cancel by User
407	Remote Arm/Disarm (Downloading)
408	Quick Arm AWAY/MAX
441	Armed STAY/INSTANT, Quick Arm STAY/INSTANT, Armed STAY
521	Bell Bypass
524	Auxiliary Relay Bypass
551	Main/Backup Dialer Bypass
570	Bypass
602	Normal Dialer Test
607	Fire Walk Test
608	Off-Normal Dialer Report

## Programming Communications Options

To program communications options, do the following:

1. With at least one Alpha keypad (6139, 6139R) connected to the system, power up the system temporarily.
2. Enter the programming mode by keying the following on the Alpha keypad: **Master code (5120) + 8 0**.

**Press \*33 BACKUP DIALER PULSE/TONE SELECTION**

Enter 1 digit (default = 0)

0 = Pulse Dial, 1 = Tone Dial. Default is **0**.

**Press \*40 PABX ACCESS CODE**

Enter up to 4 digits if PABX is needed to access an outside telephone line. If fewer than 4 digits are needed to be entered, enter them and then press \* followed by the next field number to be programmed (e.g., 41). To clear entries from this field, press \*40\*.

**Press \*41 PRIMARY PHONE No.**

Enter up to 12 digits.

If fewer than 12 digits entered, exit by pressing \* and next field number (e.g., 42). To clear entries from field, press \*41\*

**Press \*42 SECONDARY PHONE No.**

Enter up to 12 digits.

If fewer than 12 digits entered, exit by pressing \* and next field number (e.g., 43). To clear entries from field, press \*.42\*.

**Press \*43 SUBSCRIBER ACCOUNT. No.**

(Central Station Account Number).

Enter 3 or 4 digits. Enter digits 0-9; #+11 = B; # +12 = C; # +13 = D; #+14 = E; or # +15 = F. If 3-digit entry desired, enter and then press [\*] as fourth digit.

To clear entries from field, press \*43\*. See blank Programming Form for examples of Account No. entries.

**Press \*45 MAIN DIALER PULSE/TONE SELECTION**

Enter 1 digit (default = 0)

0 = Pulse Dial, 1 = Tone Dial. Default is **0**.

**Fields \*40, \*41, \*42:**  
Enter up to the number of digits shown. Do not fill unused spaces.  
Enter 0-9,  
# + 11 for '\*'  
# + 12 for '#'  
# + 13 for a pause  
(2.5 secs)

**Press \* 46 REPORT FORMAT**

Determines which format is to be used to report to the central station.

0 = 3+1; 4+1 ADEMCO Lo Speed Standard (**this is the default**)

1 = 3+1; 4+1 Radionics Standard

2 = 4+2 ADEMCO Lo Speed Standard

3 = 4+2 Radionics Standard

6 = 4+2 ADEMCO Express

7 = ADEMCO Contact ID Reporting

8 = 3+1; 4+1 ADEMCO Lo Speed Expanded

9 = 3+1; 4+1 Radionics Expanded

**Note:** The maximum number of alarm and alarm restore reports during one armed period is determined by field \* 92.

**Press \* 47 SPLIT/DUAL REPORTING**

Enter 0 to disable (Backup report only). **This is the default.**

	TO PRIMARY	TO SECONDARY
0 =	All	Used for back-up only
1 =	Alarms, Restore, Cancel	Others
2 =	All except Open/Close, Test	Open/Close, Test
3 =	Alarms, Restore, Cancel	All
4 =	All except Open/Close, Test	All
5 =	All	All

**Press \* 48 15-SECOND DIALER DELAY, BURGLARY**

Enter 0 for no, or 1 for yes. Default is **0** (no delay).  
Must be a "0" for UL burglary installations.

**Press \* 49 PERIODIC TEST REPORT**

Select the desired test report interval.

0 = none; 1 = 24 hours (default); 2 = weekly; 3 = 30 days. Test Report Code entered in field \* 64 or \* 84 is sent.

Must be "1" for fire installations

**Press \* 50 SESCOA/RADIONICS SELECT**

0 = Radionics (0-9, B-F reporting)

1 = SESCOA (0-9 only reporting)

Select 0 for all other formats. Default is **0**.

**Press \* 56 ZONE PROGRAMMING MODE**

Menu driven zone programming is where you enter report codes for hardwired zones (see *Section 5: BASIC HARDWIRED ZONES* for more information) and for system zones, such as dialer supervisory zones 11 & 12.

**TO PROGRAM  
SYSTEM STATUS  
AND RESTORE  
REPORT CODES  
(\* 58 - \* 74)**

The following is a set of guidelines to be used for programming report codes. The actual digits that you enter depend upon the particular installation, and should be agreed upon by both you and the central station office receiving the signals. Use these guidelines to program this entire section.

**With a 3+1 or 4+1 Standard Format:** Enter a code in the *first* box: 1-9, A, B, C, D, E, or F. Enter "#+10" for A (this reports a "0" on some receivers), "#+11" for B, "#+12" for C, "#+13" for D, "#+14" for E, "#+15" for F.

An entry of "0" in the *first* box will disable a report.

An entry of "0" in the *second* box will result in automatic advance to the next field when programming.

**With an Expanded or 4+2 Format:** Enter codes in *both* boxes (1st and 2nd digits) for 1-9, or A-F, as described above.

An entry of "0" in the *first* box will disable a report.

An entry of "0" in the *second* box will eliminate the expanded message for that report.

**With Ademco Contact ID Reporting:** Enter a digit in the *first* box to enable the zone to report. Use a different digit for each zone until you have used up available digits. If the number of zones exceeds the number of available digits, begin with digit 1 again. This is an "enabling" code only and is not the actual code sent to the central station office. Entries in the *second* boxes will be ignored. For system status (non-alarm) codes, enter a "1" in the *first* box for all the system conditions you want to send to the central station.

An entry of "0" in the *first* box will disable the report.

	<p>In fire installations, you must program the control to transmit fire alarm, fire supervisory (if used), trouble, AC loss, restore, and both normal and off-normal dialer test reports. In addition, test reports must be sent every 24 hours (program field *49 = 1 (default)). In fire/burglary installations, also program the control to transmit burglar alarm, open/close, and low battery reports.</p>
--	---

**Press \*58 SUPERVISORY REPORT CODE**

This will be sent when a system supervisory condition exists.

**Press \*59 SUPERVISORY RESTORE CODE**

This will be sent upon restoral of a system supervisory condition.

**Press \*60 TROUBLE REPORT CODE**

This will be sent if a zone goes into trouble.

**Press \*61 BYPASS REPORT CODE**

This will be sent when a zone is manually bypassed.

**Press \*62 AC LOSS REPORT CODE**

This report is sent at a random time between 6 and 12 hours after the AC power loss occurs. If AC restores before the report goes out, there is no AC loss report.

**Press \*63 LOW BAT REPORT CODE**

This will be sent when a low battery condition exists in the system's standby battery.

**Press \*64 NORMAL TEST REPORT CODE**

This is sent periodically to test that the communicator and phone lines are operational (frequency of report is selected in field \*49).

**Press \*65 OPEN/EXIT ALARM REPORT CODE**

OPEN EXIT

The OPEN report is sent upon disarming of the system. The 2nd digit is automatically sent as the User No., if expanded or 4+2 reporting is selected. The EXIT ALARM report is sent if an entry/exit zone remains faulted after exit time has ended, and the system is not disarmed within the new entry delay period. The 2nd digit of the EXIT ALARM REPORT is automatically sent as the 2nd digit of the zone alarm report code programmed in \*56, if expanded or 4 + 2 reporting is selected.

See TO PROGRAM SYSTEM STATUS AND RESTORE REPORT CODES explanation on previous page for fields \*66-\*74, and \*84.

**Press \*66 ARM AWAY/STAY REPORT CODE**

AWAY STAY

This option allows for independent programming of AWAY and STAY reports . 2nd digit of Report is User No., if expanded or 4+2 reporting is selected.

**Press \*68 CANCEL REPORT CODE**

This is sent upon disarming of the system after an alarm condition was reported.

**Press \*69 GROUP RESTORES FOR TROUBLE & BYPASS**

Enter 0 if a report is desired for each zone restoral, as it occurs. **This is the default.** Enter 1 if a report is not desired until all zones have restored.

Must be "0" for fire and UL burglary installations.

**Note:** "1" not applicable to Contact ID reporting.

**Press \*70 ALARM RESTORE REPORT CODE, 1st DIGIT**

This is sent when the zone that caused an alarm is restored to its non-faulted condition. 2nd digit is automatically sent as the 2nd digit of the zone alarm report code programmed in field \*56, if expanded or 4+2 reporting is selected.

**Press \*71 TROUBLE RESTORE REPORT CODE**

This is sent when a trouble in a zone is restored. Field \*69 applies.

**Press \*72 BYPASS RESTORE REPORT CODE**

This is sent when a zone that has been bypassed is un-bypassed. Field \*69 applies.

**Press \*73 AC RESTORE REPORT CODE**

This is sent when AC power has been restored after an AC power outage.

**Press \*74 LOW BAT RESTORE REPORT CODE**

This is sent when a system low battery condition is restored to normal.

**Press \*79 MAIN/BACK-UP DIALER ENABLE**

M B

This option allows you to enable the main and backup dialers independently. Enter 1 in the first box to enable the main dialer, and 1 in the second to enable the back-up dialer. Default = [1,1]



**Press \*84 MISCELLANEOUS REPORT CODES**

<input type="checkbox"/>	<input type="checkbox"/>	<input type="checkbox"/>	<input type="checkbox"/>	<input type="checkbox"/>	<input type="checkbox"/>
Fire/Burg Walk	Fire/Burg Walk	Off-Norm			
Test Start	Test End	Dialer Test			

Enter report codes for these miscellaneous reports.

**Press \*92 NUMBER OF REPORTS IN ARMED PERIOD**

“0” limits reports to 1 alarm report + 1 restore report per burglary zone while armed; “1” allows an unlimited number of alarm plus alarm restore reports. Default is 1. (This feature does not apply to fire or fire supervisory zones, for which the number of reports is unlimited.)

**Press \*94 DOWNLOAD PHONE NUMBER**

<input type="text"/>	<input type="text"/>	<input type="text"/>	<input type="text"/>	<input type="text"/>	<input type="text"/>	<input type="text"/>	<input type="text"/>	<input type="text"/>	<input type="text"/>	<input type="text"/>	<input type="text"/>
----------------------	----------------------	----------------------	----------------------	----------------------	----------------------	----------------------	----------------------	----------------------	----------------------	----------------------	----------------------

Enter up to 12 digits; 0-9, # +11 for “\*”, # + 12 for “#”, # + 13 for a pause. Do not fill unused spaces. End field by entering “\*”. To clear entries, press \*94\*.

**Press \*95 RING DETECTION COUNT FOR DOWNLOADING**

Refer to the chart below and program this field accordingly.

Answering Machine	Downloading	Field *95 Programming
No	Yes	Set for value other than “0” (1-14).
Yes	Yes	“15” to bypass answering machine.
No	No	Enter “0”
Yes	No	Enter “0”

**\*96 INITIALIZE DOWNLOAD ID AND SUBSCRIBER ACCT. No. FOR DOWNLOADING**

Automatically enters the defaults in these fields that the system requires in order to communicate with a computer for the first time through V-Link Downloading software. **Do not** enter \*97 after this, as that would void the \*96 action.

This completes the communication programming.

Exit the programming mode by pressing \*99.

Refer to *Section 16. TESTING THE SYSTEM* to check system operation.

# Section 12.

## ZONE RESPONSE TYPE DEFINITIONS

This section provides the following information:

- General information about zone response types
- Zone response types

### General Information

You must assign a zone type to each zone, which will define the way in which the system will respond to faults in that zone. Zone types are defined below.

### Zone Response Types

#### Type 00 Zone Not Used

- Program this zone type for zones that are not used.

#### Type 01 Entry/Exit Burglary

- Provides exit and entry delays whenever zone is faulted when control is armed in the Away or Stay mode.
- Provides exit delay (but **not** entry delay) when the panel is armed in the Instant or Maximum mode.
- Entry delay is programmable, but Exit delay is automatically set as follows:  
Exit Delay = Entry Delay (that has been programmed) +15 seconds.
- Usually assigned to sensors or contacts on doors through which primary entry and exit will take place.

Exit delay begins whenever the control is armed, regardless of the arming mode selected.

#### Type 03 Perimeter Burglary

- Provides instant alarm if the zone is faulted when the panel is armed in the Away, Stay, Instant or Maximum modes.
- Usually assigned to all sensors or contacts on exterior doors and windows.

#### Type 04 Interior Follower

- Provides a delayed alarm (using the programmed Entry/Exit time) if the Entry/Exit zone is faulted first. Otherwise this zone type gives an instant alarm.
- Active when the panel is armed in the Away and Maximum modes.
- **Bypassed automatically when the panel is armed in the Stay or Instant modes.**
- Usually assigned to a zone covering an area such as a foyer, lobby, or hallway through which one must pass upon entry and exit after the system is armed or before the system is disarmed.



This zone type is designed to provide an instant alarm if an entry/exit zone is not violated first. Therefore, it will protect an area in the event an intruder hides on the premises prior to the system being armed, or gains access to the premises through an unprotected area.

**Type 05  
Trouble by Day/  
Alarm by Night**

- Provides instant alarm if faulted when armed (night mode).
- Provides instant latched trouble sounding at the keypad(s) (and a central station report, if programmed when the system is in the disarmed state (day mode).
- Usually assigned to a zone which contains a foil-protected door or window (such as in a store), or to a zone covering a "sensitive" area such as a stock room, drug supply room, etc., or on a sensor or contact in an area where immediate notification of entry is desired.

**Type 06  
24-hour Silent Alarm**

- Sends a report to the Central Station (must be programmed), but provides no keypad display or sounding.
- Usually assigned to a zone containing an Emergency button.

**Type 07  
24-hour Audible Alarm**

- Provides an alarm sound at the keypad and an audible external alarm.
- Sends a report to the Central Station (if programmed).
- Usually assigned to a zone that has an Emergency button.

**Type 08  
24-hour  
Auxiliary Alarm**

- Provides an audible alarm at the keypad only. **No bell output is provided.**
- Sends a report to Central Station (if programmed).
- Usually assigned to a zone containing a button for use in personal emergencies, or to a zone containing non-fire related monitoring devices such as temperature sensors, etc.

**Type 09  
Fire Alarm  
Without Verification**

- Provides a fire alarm when zone is shorted.
- Provides a trouble response when zone is open.
- Can be bypassed only by the installer (Master Code).
- Bell output for fire can be programmed as either pulsing or steady (field \*77)

**Type 10  
Interior w/Delay**

- Provides entry and exit delay times.
- Bypassed automatically when panel is armed in the Stay or Instant mode. *No entry delay* is provided if tripped when the panel is armed in the Maximum mode. *Exit* delay is present for *any* arming mode.

**Type 16  
Fire Alarm  
With Verification**

- Provides a fire alarm when zone is shorted, but only after alarm condition has been verified. This is done as follows:  
After initial short circuit is detected, zone is reset for 6 seconds. A subsequent short circuit within 90 seconds triggers a fire alarm.
- Provides a trouble response when zone is open.
- Can be bypassed only by the installer (Master Code).
- Bell output for fire can be programmed as either pulsing or steady (field \*77)

**Type 17  
Fire Waterflow Alarm**

- Provides a fire alarm when zone is shorted for longer than the time programmed in field \*78 delay time setting. For fire installations, the combined sensor and program field \*78 must not exceed 90 seconds .
- Provides a trouble on an open circuit.
- Usually assigned to a zone containing a fire sprinkler waterflow sensor.
- Bell output may be programmed to remain latched on alarm or to restore when zone restores (see field \*76)..

**Type 18  
Fire Sprinkler  
Supervisory**

- Provides a supervisory indication when a zone is shorted for longer than the time programmed in field \*78 delay time setting when a delay is enabled in field \*57. For fire installations, the combined sensor and program field \*78 must not exceed 90 seconds .
- Provides either a trouble (field \*32 = 0) or a supervisory (field \*32 = 1) on an open circuit.
- No bell output is is provided.
- Usually assigned to a zone containing a fire sprinkler supervisory sensors such as Post-Indicator-Value sensors.

**Type 19  
24-Hr. Trouble**

- Provides a trouble response on an open or short circuit, and on system zone faults.
- Usually assigned to system zones such as Zone 10 (earth ground fault) and Zone 11 (main dialer fault).

## Section 13. DATA FIELD DESCRIPTIONS

### Description of System Data Fields

THE BLANK PROGRAMMING FORM INCLUDED WITH THIS MANUAL SHOULD BE USED TO RECORD THE DATA FOR THIS INSTALLATION

#### Defaults (where applicable) Are Indicated In Text

The following is a table containing a list of all data fields in this control (presented in numerical order). If you have performed the programming instructions that were included with the installation of each of the various peripheral devices covered in previous sections, this table will simply serve as a reference for all data fields in the system. If you have decided to program all the data fields in the system at one time (and therefore did not perform the programming indicated previously in each section), you can use this table to program all the data fields now.

- \*20    **MASTER CODE**   
The Master code allows full control over system operation and is intended for installer use only. The installer should program a User #2 code for the system's primary end user. See the *SYSTEM OPERATION* section for more information. Default is **5 1 2 0**.
- \*21    **QUICK ARM ENABLE**   
If enabled, the [#] key can be used instead of the User Code when **arming** the system.  
Enter 0 for disabled or 1 for enabled. Default is **0**.
- \*23    **FORCED BYPASS FUNCTION**   
This feature allows all faulted zones to be bypassed automatically. All zones that are bypassed by this function will be displayed after the bypass is initiated:  
0 = No forced bypass. **This is the default.**  
1 = Allows automatic bypass of all open zones.
- \*27    **OUTPUT TO LONG RANGE RADIO** (e.g., No. 7720 PLUS)   
*\*This option is for future use and has not been evaluated by UL. It must be disabled ( set to "0" ; this is the default setting)*

If output to LRR is selected here, all messages that are programmed to go to the primary telephone line receiver will also be sent to the 7720 PLUS radio. These messages will always be in Contact ID format (not affected by entry in field \*46). The data line is supervised as well as certain functions in the radio.

If communication is lost or a trouble develops, the system will attempt to send a message via both radio and telephone to the central station. Trouble restore report (\*71) is sent on restore of the condition.

Enter the first digit of the Trouble dialer report for loss of contact with the radio; enter 1–9, B (# +11), C (# +12), D (# +13), E (# +14), or F (# +15). The 2nd digit of Trouble Dialer Report is automatically the 2nd digit from field \*60.

**Note:** The Radio should be programmed for device address 3 on the keypad lines.

**MISCELLANEOUS  
OPTIONS  
(\*28-\*39)**

- \*28 SINGLE ALARM SOUNDING PER ZONE** (per armed period)   
This field limits alarm sounding to once per arming period for a given zone. Enter 1 for yes; default is 0 (no).

**UL** For UL installations, enter 0 for unlimited Alarm Soundings.

- \*30 ALARM BELL TIMEOUT**   
This field determines whether the bell output will shut off after time allotted, or continue until manually turned off. Enter as follows:  
0 = No timeout (default); 1 = 4 min; 2 = 8 min; 3 = 12 min; 4 = 16 min.  
Fire bell must be programmed to sound at least 5 minutes.
- \*31 AUXILIARY RELAY TIMEOUT**   
This field determines whether the auxiliary relay will shut off after time allotted, or continue until manually turned off. Enter as follows:  
0 = No timeout; 1 = 4 min; 2 = 8 min; 3 = 12 min; 4 = 16 min (default).
- \*32 SUPERVISORY OPEN/SHORT**   
Select response of open and short circuits on zones programmed for fire supervisory response (type 18). Enter "0" for trouble on open/supervisory on short (default), "1" for supervisory on open or short.
- \*33 BACK-UP DIALER PULSE/TONE**   
Enter "0" for pulse (default), "1" for tone dial.
- \*34 AUXILIARY RELAY FUNCTION**   
Enter "0" for Trouble/Supv; "1" for Alarm activation, silenced by Code + OFF (default); "2" for Smoke Detector Reset; "3" for Battery Save option; 4 for Alarm activation, silenced by code + #67 (can be used for elevator recall).

 When function 1 or 4 is selected, program fields \*85 and \*86 to select zones which will trigger the aux. relay. When function 1 is selected, program aux. relay timeout in field \*31.

- \*35 AUXILIARY RELAY ARMING DING**   
Enter "0" to disable (default); "1" to enable momentary confirmation of arming on auxiliary relay output. If enabled, field \*34 must also be set to "1."
- \*36 ZONE 4 ALT TAMPER FUNCTION**   
Enter "0" to disable (default); "1" to enable zone 4 as a tamper zone. If enabled, program zone 4 for Day Trouble/Night Alarm (zone type 5) or 24-hr. Audible response (zone type 7) in field \*56.
- \*37 PS24 MOD AC/LOW BAT INTERFACE**   
Enter "0" to disable (default); "1" to enable system to monitor low battery and AC loss conditions from PS24 module instead of the control's internal circuitry. If enabled, wire PS24 Low Batt & AC outputs to J5 header (pins 8 & 9)
- \*38 ZONE TYPE 01 ENTRY DELAY**   
System will wait the time allotted before sounding alarm upon entering. May be selected individually  
0 = 0 seconds    2 = 30 seconds    4 = 60 seconds  
1 = 20 seconds    3 = 45 seconds    5 = 90 seconds  
Default is 2 (30 seconds).  
(EXIT delays = Zone type 01 Entry delay plus 15 seconds).

**DIALER  
PROGRAMMING  
(\*40-\*50)**

**Fields \*40, \*41, \*42:**  
Enter up to the number of digits shown. Do not fill unused spaces.  
Enter 0-9,  
# + 11 for '\*'  
# + 12 for '#'  
# + 13 for a pause  
(2.5 secs)

**\*39 AUDIBLE EXIT WARNING**   
If enabled, this field provides exit warning sound when armed AWAY; Warning sound consists of slow continuous beeps until last 5 seconds, when it changes to fast beeps. The warning sound will end at the termination of Exit time.  
0 = no; 1 = yes. Default is **1**.

**\*40 PABX ACCESS CODE** (See Box at Left)   
Enter up to 4 digits if PABX is needed to access an outside line. If fewer than 4 digits are needed to be entered, exit by pressing \* and next field number (e.g., 41). To clear entries from field, press \*40\*.

**\*41 PRIMARY PHONE No.** (See Box at Left)   
Enter up to 12 digits. If fewer than 12 digits entered, exit by pressing \* and next field number (e.g., 42). To clear entries from field, press \*41\*.

**Note:** Back-up reporting (5 calls are made to the secondary phone number if no kiss-off is received after 5 attempts to the primary number) is automatic only if there is a secondary phone number (field \*42).

**\*42 SECONDARY PHONE No.** (See Box at Left)   
Enter up to 12 digits. If fewer than 12 digits entered, exit by pressing \* and next field number (e.g., 43). To clear entries from field, press \*42\*. See note above, also.

**\*43 SUBSCRIBER ACCOUNT No.**  Primary Receiver. See notes above.  
Enter digits 0-9; # +11=B; # +12=C; # +13=D; # +14=E; or # +15=F. Enter \* as the fourth digit if a 3-digit account number (for 3+1 dialer reporting format) is used. Enter 0 as the first digit of a 4-digit account number for Nos. 0000-0999. Exit field by pressing \* (and press next field number) if only 3 digits are used. To clear entries from field, press \*43\*.  
See blank Programming Form for examples of Account No. entries.

**\*45 MAIN DIALER PULSE/TONE**   
0 = Pulse Dial (default); 1 = Tone Dial

**\*46 REPORT FORMAT**   
Determine which format is to be used to report to the central station. Enter 1 digit (0-9).  
0 = 3+1; 4+1 ADEMCO Lo Speed Standard (**this is the default**)  
1 = 3+1; 4+1 Radionics Standard  
2 = 4+2 ADEMCO Lo Speed Standard  
3 = 4+2 Radionics Standard  
6 = 4+2 ADEMCO Express  
7 = ADEMCO Contact ID Reporting  
8 = 3+1; 4+1 ADEMCO Lo Speed Expanded  
9 = 3+1; 4+1 Radionics Expanded  
(Enter \* as the 4th digit of \*43, if 3+1 dialer reporting is to be used.)

For an explanation of these formats, see *Section 11. SYSTEM COMMUNICATION*.

**Note:** The maximum number of alarm and alarm restore reports during one armed period is determined by field \*92.

**\*47 SPLIT/DUAL REPORTING**

Enter 0 to disable (Backup report only). **This is the default.**

	TO PRIMARY	TO SECONDARY
0 =	All	Back-up Reporting Only
1 =	Alarms, Restore, Cancel	Others
2 =	All except Open/Close, Test	Open/Close, Test
3 =	Alarms, Restore, Cancel	All
4 =	All except Open/Close, Test	All
5 =	All	All

**\*48 15-SECOND DIALER DELAY (BURGLARY)**

If selected, will provide 15-second delay of burglary alarm report to the central station. Allows time for subscriber to avoid a false alarm transmission.

Enter 0 for no or 1 for yes. Default is **0** (no delay).

Must be "0" for UL burglary installations.

**\*49 PERIODIC TEST REPORT**

Select the desired test report interval.

0 = none; 1 = 24 hours (default); 2 = weekly; 3 = 30 days.

Test Report Code entered in field \*64 or \*84 is sent.

Must be "1" for fire installations.

**\*50 SESCOA/RADIONICS SELECT**

0 = Radionics (0-9, B-F reporting)

1 = SESCOA (0-9 only reporting)

Select 0 for all other formats. Default is **0**.

**\*51 CONFIRMATION OF ARMING DING FOR BELL**

Enter 1 to enable 1/2 second external alarm sounding "ding" when closing report goes in, or at the end of exit delay. **0** disables the "ding" (default).

**\*56 ZONE ASSIGNMENT/ALARM REPORT CODES**

*REFER TO THE ZONE ASSIGNMENT TABLE FOR \*56 IN THE CENTERFOLD PROGRAMMING FORM.*

This is an interactive menu mode that is used to program zone numbers, zone types, alarm and report codes, and for entering Alpha descriptors for zones (we recommend entering descriptors in menu mode \*82).

Upon entering menu mode \*56, the following is displayed:

```

Enter Zn Num.
(00 = Quit)      20
  
```

Zone 20 entered ↑

```

Zn  ZT  RC
20  09  10
  
```

↓ Zone Number

```

20 Zone Type
Perimeter      03
  
```

Zone Type ↑

**Zone Number (Zn):** Enter the zone number that you wish to program (or [0][0] to leave zone programming).

Press [\*]. A summary display will come up, showing the status of that zone's program.

If it is programmed satisfactorily, press [#] to back up one step and enter another zone number, if desired.

If the zone is not programmed, or you want to change it, press [\*]. A prompt for Zone Type will appear.

**Zone Type (ZT):** Each zone must be assigned to a zone type, which defines the way in which the system responds to faults in that zone.

Enter the zone type code (or change it, if necessary). Zone types are listed below.



00 = Not Used	06 = 24 Hr Silent	16 = Fire W/Verif.
01 = Entry/Exit #1	07 = 24 Hr Audible	17 = Fire Waterflow
03 = Perimeter	08 = 24 Hr Aux	18 = Fire Sprinkler
04 = Interior Follower	09 = Fire W/O Verif.	Supv.
05 = Trouble Day/Alarm Night	10 = Interior w/Delay	19 = 24-Hr. Trouble

Default values for zones 01 to 05 are:

Zone No.(Zn):	01	02	03	04	05
Zone Type Default:	09	09	09	09	09

When the display shows the zone type you want, press [\*] to advance to...

20 Report Code 1st 00 2nd 00 00
------------------------------------

**Report Code (RC):** The report code consists of 2 hexadecimal digits, each in turn consisting of 2 numerical digits. For example, for a report code of "3C", enter [0][3] for "3" and [1][2] for "C".

Enter the numbers and press [\*] to advance to...

**The Summary Screen.** This will reappear, showing the programming changes that were made. Press \* to continue.

Program Alpha? 0 = No 1 = Yes 0
------------------------------------

**Custom Alpha Editing:** For all zone types, the next request is to enter Alpha descriptors for the zones. The entry may be done now (enter 1), or may be done at a later time via \*82 mode (enter 0).

See *Section 10: ALPHA DESCRIPTION PROGRAMMING* for procedure.

Enter Zn Num. (00 = Quit) 00
---------------------------------

When all entries to be made for the zone at this time are complete, the next zone number can be entered for programming, or zone programming can be ended by entering [0][0] as the next "zone number".

*Zone entries can be reviewed by pressing [#][5][6]. Changes cannot be made here, so this is safer for review. Enter the first zone number to be viewed and press [#]. To view each zone, press [#] and the zone number will advance to the next programmed zone. When the end of the list is reached, press [0][0] to exit. This method of exiting may also be done at any time during the review.*

\*57

**Zone Type 18 Delay Enable**

0 = Disable delay (ignore delay programmed in field \*78)

1 = Enable delay ( use delay programmed in field \*78) (default)

**TO PROGRAM SYSTEM  
STATUS AND  
RESTORE REPORT  
CODES  
(\* 58 - \* 74)**

The following is a set of guidelines to be used for programming report codes. The actual digits that you enter depend upon the particular installation, and should be agreed upon by both you and the central station office receiving the signals. Use these guidelines to program this entire section.

**With a 3+1 or 4+1 Standard Format:** Enter a code in the *first* box: 1-9, A, B, C, D, E, or F. Enter "#+10" for A (this reports a "0" on some receivers), "#+11" for B, "#+12" for C, "#+13" for D, "#+14" for E, "#+15" for F.

An entry of "0" in the *first* box will disable a report.

An entry of "0" in the *second* box will result in automatic advance to the next field when programming.

**With an Expanded or 4+2 Format:** Enter codes in *both* boxes (1st and 2nd digits) for 1-9, or A-F, as described above.

An entry of "0" in the *first* box will disable a report.

An entry of "0" in the *second* box will eliminate the expanded message for that report.

**With Ademco Contact ID Reporting:** Enter a digit in the *first* box to enable the zone to report. Use a different digit for each zone until you have used up available digits. If the number of zones exceeds the number of available digits, begin with digit 1 again. This is an "enabling" code only and is not the actual code sent to the central station office. Entries in the *second* boxes will be ignored. For system status (non-alarm) codes, enter a "1" in the first box for all the system conditions you want to send to the central station.

An entry of "0" in the *first* box will disable the report.

**Press \*58 SUPERVISORY REPORT CODE**

This will be sent when a system supervisory condition exists.

**Press \*59 SUPERVISORY RESTORE CODE**

This will be sent upon restoral of a system supervisory condition.

**Press \*60 TROUBLE REPORT CODE**

This will be sent if a zone goes into trouble.

**Press \*61 BYPASS REPORT CODE**

This will be sent when a zone is manually bypassed.

**Press \*62 AC LOSS REPORT CODE**

This report is sent at a random time between 6 and 12 hours after the AC power loss occurs. If AC restores before the report goes out, there is no AC loss report.

**Press \*63 LOW BAT REPORT CODE**

This will be sent when a low battery condition exists in the system's standby battery.

**Press \*64 NORMAL TEST REPORT CODE**

This is sent periodically to test that the communicator and phone lines are operational (frequency of report is selected in field \*49). The 5120XM will transmit a normal dialer test code when no pre-existing alarm, supervisory, or trouble conditions exist. The system will transmit an off-normal dialer test code (field \*84) if such conditions are present at the time the report is transmitted.

**Press \*65 OPEN/EXIT ALARM REPORT CODE**

OPEN EXIT

The OPEN report is sent upon disarming of the system. The 2nd digit is automatically sent as the User No., if expanded or 4+2 reporting is selected. The EXIT ALARM report is sent if an entry/exit zone remains faulted after exit time has ended, and the system is not disarmed within the new entry delay period. The 2nd digit of the EXIT ALARM REPORT is automatically sent as the 2nd digit of the zone alarm report code programmed in \*56, if expanded or 4 + 2 reporting is selected.

**RESTORE  
REPORT CODES  
(\*69-\*74)**

- \*66 ARM AWAY/STAY REPORT CODE**

This option allows for independent programming of AWAY and STAY reports. 2nd digit of report is User No. if expanded or 4+2 reporting is selected.
- \*68 CANCEL REPORT CODE**

This is sent when the control is disarmed from an alarm state.
- \*69 GROUP RESTORES FOR TROUBLE AND BYPASS**

Enter 0 for no (report for each restore), or 1 for yes (report after all zones restored). Default is "0". **Note:** "1" not applicable to Contact ID reporting. Must be "0" for fire and UL burglary installations.
- \*70 ALARM RESTORE REPORT CODE, 1st DIGIT**

2nd digit is automatically sent as the 2nd digit of the zone alarm report code programmed in field \*56, if expanded or 4+2 reporting is selected.
- \*71 TROUBLE RESTORE REPORT CODE**

This is sent when a trouble in a zone is restored. Field \*69 applies.
- \*72 BYPASS RESTORE REPORT CODE**

This is sent when a zone that has been bypassed is un-bypassed. Field \*69 applies.
- \*73 AC RESTORE REPORT CODE**

This is sent when AC power to the control has been restored.
- \*74 LOW BAT RESTORE REPORT CODE**

This is sent when a system low battery condition has been restored.
- \*76 WATERFLOW ALARM SILENCING**

Determines when Waterflow alarm zones will be silenced.  
Enter "0" for manual silence only (Code + Off); "1" for automatic silencing when zone restores. Default is 0.  
Automatic silence option may only be used with permission of local AHJ.
- \*77 ALARM BELL SOUND**

Enter "0" for pulsing (default), "1" for steady.  
If "0" is entered, the bell will pulse using the NFPA 3-pulse temporal pattern.
- \*78 ZONE TYPES 17 & 18 DELAY**

00 – 99 seconds. Default is 00.  
Zone Type 18 Delay must be enabled in field \*57. The combined sensor and field \*78 delay must not exceed 90 seconds.
- \*79 MAIN/BACKUP DIALER ENABLE**

Enter "1" to enable each dialer (default), "0" to disable.
- \*82 CUSTOM ALPHA EDITING**

See *Section 10. ALPHA DESCRIPTION PROGRAMMING* for procedure.
- \*84 MISCELLANEOUS REPORT CODES**

Enter report codes for Fire /BurgWalk Test Start, Fire/Burg Walk Test End, and Off-Normal Dialer Test.

**\*85 ZONES 1-7 BELL & AUX. RELAY ACTIVATION**

Enter the Bell/Aux relay assignments for zones as follows:  
 0 = none; 1 = bell; 2 = aux. relay; 3 = bell & aux. relay  
 (Defaults are 1, 1, 1, 1, 1, 0, 0.)

**\*86 ZONES 10-12, 95 & 96 BELL & AUX. RELAY ACTIVATION**

Enter the Bell/Aux relay assignments for zones as follows:  
 0 = none; 1 = bell; 2 = aux. relay; 3 = bell & aux. relay  
 (Defaults are 0, 0, 0, 0, 0, 0.)

**Installer must enter "0" in the first box. The second box represents zone 10.**

**\*87 BURGLARY FEATURE ENABLE**

Enter "0" to Disable arming & chime features; "1" to Enable (default)

**\*92 NUMBER OF REPORTS IN ARMED PERIOD**

This option can be used to limit the number of messages (alarm & alarm restore reports) sent to the central station in an armed period. "0" limits reports to 1 alarm + alarm restore per zone; "1" allows an unlimited number of reports. Applies to burglary zones only. Default is 1.

**DOWNLOAD INFORMATION (\*94, \*95)**

**\*94 DOWNLOAD PHONE NUMBER**

Enter up to 12 digits; 0-9, # +11 for "\*", # + 12 for "#", # + 13 for a pause. Do not fill unused spaces. End field by entering \*. To clear entries from field, press \*94\*.

**\*95 RING DETECTION COUNT FOR DOWNLOADING**

Enter number of rings before control picks up phone line (or 0 or 15). Refer to the chart below and program this field accordingly.

Answering Machine	Downloading	Field *95 Programming
No	Yes	Set for value other than "0" (1-14).
Yes	Yes	"15" to bypass answering machine.
No	No	Enter "0"
Yes	No	Enter "0"

**\*96 INITIALIZE DOWNLOAD ID AND SUBSCRIBER ACCT. No. FOR DOWNLOADING**

(No data entry required, press \*96)

**\*97 SET ALL PROGRAM FIELDS TO DEFAULT VALUES**

(No data entry required, pressing \*97 automatically loads all defaults).

**TO EXIT PROGRAMMING MODE (\*98 or \*99)**

**\*98 EXITS PROGRAMMING MODE and prevents re-entry by : Master Code + 8 + 0.**

**\*99 EXITS PROGRAMMING MODE and allows re-entry by: Master Code + 8 + 0 or by: Power-up, then "\*" and "#" simultaneously.**

# Section 14. REMOTE PROGRAMMING AND CONTROL (DOWNLOADING)

## General Information

The Ademco 5120XM can be remotely programmed from an IBM compatible Personal Computer (PC), a HAYES Modem, and Ademco's V-LINK® Software (as specified below).

Programming the control from a remote location is protected against compromise by someone attempting to defeat the system, using multi-levels of security protection:

- 1. Security Code Handshake:** An 8-digit Download ID code must be matched between the control and the downloader .
- 2. Site Initiated Remote Programming:** The installer initiates the callback from the subscriber premises (by entering Master code + # + 1) while disarmed. All parameters can then be downloaded via the phone lines using a personal computer.
- 3. Station Initiated Remote Programming:** The operator calls the site from your office to initiate the download call. The control hangs up and then calls back the PC via the preprogrammed telephone number. The unit can then be uploaded, downloaded, or controlled from your office .
- 4. Data Encryption:** Data passed between the PC and the control is encrypted for security so that it is very difficult for a foreign device tapped

**UL**

Remote programming may only be performed when a service technician is at the site during downloading.

## Equipment Required

### At the premises:

Ademco 5120XM and keypad.

### At the installer's office/home:

An IBM PC compatible computer.

*Either* a HAYES brand SMARTMODEM 1200 [Level 1.2 or higher external or Level 1.1 or higher (with 4 position DIP switch) internal style], *or* a HAYES brand Optima 24 Plus FAX96 Modem (set Aux Modem command to: X&D2&C1&Q0N).

V-LINK® Downloading Software Diskette (at revision level 3.1 or higher).  
Appropriate interconnecting cables.

## Initial Download

### Site Initiated:

1. Enter program mode by entering Master code (5120) + 8 + 0.
2. Program the download phone number in field \*94.
3. Initialize the download ID and subscriber account number by entering \*96.
4. Exit program mode by entering \*98 (prevents re-entry using Master code) or \*99 (allows re-entry using Master code).
5. Wait approx. 1 minute for system to stabilize. Then initiate the downloading session by entering Master code + # + 1 (this causes the control to make the phone call).

### Central Station Initiated:

1. Enter program mode by entering Master code (5120) + 8 0.
2. Program the download phone number in field \*94.
3. Program the ring detect count to "4" in field \*95. The central station can change this as required when on-line with the control.
4. Initialize the download ID and subscriber account number by entering \*96.
5. Exit program mode by entering \*98 (prevents re-entry using Master code) or \*99 (allows re-entry using Master code).
6. Wait approx. 1 minute for system to stabilize. Then the central station can initiate the downloading session by calling the control.

### Remote Programming Information

The downloading system can perform many functions when in communication with the control unit. Besides uploading and downloading, the status of the system can be observed and various commands can be initiated, as follows:

Arm the System in the Away Mode; Disarm the System.

Bypass a Zone.

Force the System to Accept a New Program Download.

Shut Down Communication (dialer) Functions (non-payment of monitoring fees in an owned system).

Shut Down all Security System Functions (non-payment for a leased system).

Inhibit Local Keypad Programming (prevents account takeover).

Command the System to Upload a Copy of its Resident Program to the office.

Read: Arming Status, AC Power Status, Lists of Faulted Zones, Bypassed Zones, Zones Currently in Alarm, and Zones Currently in Trouble.

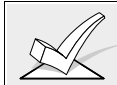

After the control and the PC have established valid communication, each keypad on the system will become inactive and will display "C C" or "MODEM COMM.". The keypads will become active after the download communication is terminated. The detailed operation of the download functions is covered in the installation instructions for the V-LINK® Downloading Software Diskette.

### Remote Programming Advisory Notes

The control does not scan zones for faults and ignores keypad entries while the control is in communication with the downloading computer.

A copy of the program downloaded may be produced from the IBM PC compatible computer, using the product's internal report generator, when an optional printer is connected (consult your PC manual for proper printer and connections).

Program upload time: 1 minute 30 seconds for a complete program.  
Program download time — varies depending on changes — 2 minutes 40 seconds for a complete program.

# Section 15. SYSTEM OPERATION

This section provides the following information:

- User Codes
- Keypad functions
- Panic keys

## User Codes

This system provides 1 Master code, 5 secondary codes (Users 2-6), and 1 duress code (User 8) These are described below.

### Master Code

The installer programs the 4-digit Master Code initially as part of the programming procedure. The factory default Master code is "5120", but may be changed in field \*20. The master code is intended for use by the installer only. The installer must program a User #2 code for use by the system's primary end user.

The Master code is the only code that is allowed entry into programming mode and also, in normal operation mode, is used to enter the other user codes, which are allowed access to the normal functions of the system.

### Secondary User Codes

In normal operation mode, the Master user code can be used to assign up to 5 secondary 4-digit user codes, as well as 1 duress code. It can also be used to remove secondary codes from the system (individually).

**To assign (or change) a Secondary user code**, enter (via keypad):

Master Code + [CODE key] + User # (2-6 or 8) + desired Secondary Code

The system will emit a single beep when each secondary code has been successfully entered.

**To delete a Secondary user code**, enter (via keypad):

Master Code + [CODE key] + User # (2-6 or 8)



- 1. All Master and Secondary user codes permit access to the system for arming, disarming, etc.
- 2. If a secondary code is inadvertently repeated for different users, the lower user number will take priority.
- 3. Opening and closing reports are sent for the Master code as User No. 1, with the appropriate subscriber account number. Secondary user codes are sent as User Nos. 2 through 6 and 8, respectively, with the appropriate subscriber account number.

**USER CODE FUNCTION SUMMARY TABLE**

USER #	ENTER PROGRAM MODE	ARM/DISARM BURG ZONES	SILENCE ALM, SUPV, & TRBLE	ADD/CHANGE USERS	BYPASS ZONES	ENTER TEST MODES
1 (MASTER)	YES	YES	YES	YES, USERS 1-8	ALL	FIRE & BURG WALK, FIRE DRILL
2 (MAIN USER)	NO	YES	YES	YES, USERS 2-8	BURG	BURG WALK & FIRE DRILL
3-6	NO	YES	YES	NO	BURG	BURG WALK TEST
8 (DURESS)	NO	YES, SENDS SILENT PANIC ALARM	YES	NO	NO	NO

## Keypad Functions

The keypad allows the user to arm and disarm the system, and perform other system functions, such as bypassing zones, and display zone descriptors. Zone and system conditions (alarm, trouble, bypass) are displayed in the Display Window.

Note that if you enabled QUICK ARM (field \*21), the [#] key can be pressed instead of entering the user code, for any of the arming procedures (Away, Stay, Instant, Maximum, etc.). The user code is *always* required, however, when disarming the system.

### Arming Functions

The following is a brief list of system commands. For detailed information concerning system functions, refer to the User's Manual.

#### SUMMARY OF SYSTEM COMMANDS

<b>Arming Away</b>	Code + AWAY [2].
<b>Arming Stay</b>	Code + STAY [3].
<b>Arming Instant</b>	Code + INSTANT [7].
<b>Arming Maximum</b>	Code + MAXIMUM [4].
<b>Disarming</b>	Code + OFF [1].
<b>Silencing Sounders</b>	Code + OFF [1].
<b>Resetting Smoke Detectors and Clearing Alarm Memory</b>	Code + OFF [1] twice.
<b>Bypassing Zones</b>	Code + BYPASS [6] + zone number(s).
<b>Unbypassing Zone Types 9, 16, 17, 18, 19, and System Zones 6 and 10-13</b>	Code + BYPASS [6] + zone numbers
<b>Un-bypassing Other Zones</b>	Code +OFF [1]
<b>Fire Walk Test Mode</b>	Master Code + # + 68 (Code + OFF to exit)
<b>Fire Drill Mode</b>	Master or User #2 Code + # + 69 (Code + OFF to exit)
<b>Displaying Faulted Zones</b>	Before arming, the system must be in the READY condition (all zones must be intact). If the "NOT READY" message appears, press the READY [*] key to display faulted zones.
<b>Forced (Quick) Bypass</b>	<i>(If enabled)</i> To automatically bypass all faulted zones, use the "Quick Bypass" method: Enter code + BYPASS, then wait for all open zones to be displayed. Arm when display indicates "bypass" and "ready to arm".
<b>Chime Mode</b>	Enter Code + CHIME [9]. To turn chime off, enter Code + [9] CHIME again.



Only the Master code can be used to bypass hard-wired zones programmed for fire alarm (types 9, 16, 17), fire supervisory (type 18) responses, 24 hr. trouble zones (type 19), and system zones 6 and 10-13. Bypasses on these zones can only be removed by re-entering the bypass command. Bypasses on other zones can be removed by entering the User code + OFF.



## SUMMARY OF ARMING MODES

Arming Mode	Features for Each Arming Mode			
	Exit Delay	Entry Delay	Perimeter Armed	Interior Armed
AWAY	Yes	Yes	Yes	Yes
STAY	Yes	Yes	Yes	No
INSTANT	Yes	No	Yes	No
MAXIMUM	Yes	No	Yes	Yes

### Panic Keys

There are three panic key pairs or (on some keypads) lettered keys that, if programmed, can be used to manually initiate alarms and send a report to the central station.

Each can be individually programmed for 24-hour Silent, Audible, Personal or Fire Emergency responses. The panic function is activated when both keys of the appropriate key pair are pressed at the same time, or the appropriate lettered key is pressed for at least 2 seconds.

The panic functions are identified by the system as follows:

Keys	Displayed as Zone
[1] & [*], or [A]	95
[*] & [#], or [B]	7
[3] & [#], or [C]	96



1. Key [D], if present, is not active here.
2. For the Silent Panic functions to be of practical value, the system must be connected to a central station.

## Section 16. TESTING THE SYSTEM

This section provides the following information:

- An explanation of the following test modes:
  - Battery test
  - Dialer test
  - Fire Drill test
  - One Man Fire Walk test
  - Burglary Walk test
  - Armed Burglary System test
- Turning the system over to the user

### Battery Test

When AC power is present, the PS24 will run a brief battery test every 60 seconds to determine if there is a battery connected, and will run an extended battery test every 17 hours to check on the battery's condition. If the PS24 finds that the battery voltage is low (less than approx. 23V) during one of these tests, it will open circuit its low battery output, which causes the 5120XM to initiate a keypad "System LoBat" display and a rapid keypad beeping sound. The 5120XM will also send a low battery report to the central station (if the dialer feature is used). (The PS24's Low Battery output must be wired to the 5120XM's J5 header pin 9 and field \*37 must be set to "1".)

The keypad can be cleared by entering any user code + OFF, and a restore report will be sent to the central station after a subsequent test indicates that the problem (disconnected or low battery) has been corrected.

### Dialer Test

The 5120xm may be programmed to automatically transmit test reports to a central station at intervals ranging from once per 24 hours to once per month. The 5120XM transmits its first test report 12 hours after initial power up, 12 hours after exiting program mode, or 12 hours after the end of a downloading session, whichever applies. The 5120XM will transmit a normal dialer test code (field \*64) when no pre-existing alarm, supervisory, or trouble conditions exist. The system will transmit an off-normal dialer test code (field \*84) if such conditions are present at the time the report is transmitted. UL requires that a test report be transmitted at least once every 24 hours (field \*49) for central and remote station fire installations.

### Fire Drill Test (Master or User 2 code + [#] + 69)

This test causes external alarm sounders to be activated (in either steady or pulsing manner as programmed for the bell) for the purpose of conducting a fire drill or a bell test. This test can only be activated by the master code or by user #2, by entering the corresponding user code and pressing [#] + 69 while the burglary portion of the system is disarmed. Keypads will display "FIRE DRILL ACTIVE" (alpha keypads) or "TEST dF" (fixed keypads) while this test is active. The test may be stopped by entering any user code and pressing OFF. Note that the system continues to monitor all 24 hour zones (fire, panic, etc.) while this test is active, and will end the test when an alarm condition is detected. This test should be conducted at periodic intervals as determined by the local authority having jurisdiction.

### One Man Fire Walk Test (Master code + [#] + 68)

This test causes the system to sound keypad beeps and bell dings in response to fire zone faults (zone type 9, 16 & 17) for the purpose of allowing proper zone operation to be checked without triggering alarms. Note that the system will not be operational as an alarm system (i.e. cannot sense alarms) while this test is active. The test can only be activated by entering the master code and pressing [#] + 68 while the burglary portion of the system is disarmed. This test should be conducted at periodic intervals as determined by the local authority having jurisdiction.

When this test is first activated, the system will sound fire bells for 3 seconds and will light all keypad indicators and display window segments to verify that they are working properly. The system will send a Walk Test Start report to the central station. The keypads will then display "Fire Walk Test in Progress" (alpha keypads) or "TEST CF" (fixed word keypads), and will sound a single beep every 15 seconds while this test is active.

Fault and reset each fire alarm sensor (zone types 9, 16, and 17) in turn. Each action should cause keypads to beep and fire bells to ding. (The auxiliary relay will also ding if set for Alarm function "1" in field \*34 and if assigned in field \*85 to the fire zone that was faulted.) The keypads will display the zone number and the associated alpha descriptor while the zone remains faulted. The system automatically issues a smoke detector power reset about 10 seconds after it finds a fault on one of these zones, to allow faulted detectors to be reset.

To end the test, enter any user code and press OFF. Note that the test will automatically end if no faults are detected within a 30 minute time period. The system will send a Walk Test End report to the central station when the test is ended.

### **Burglary Walk Test (code + TEST [5])**

This test causes the system to sound keypad beeps in response to faults on burglary and non-fire related 24 hour zones for the purpose of allowing proper zone operation to be checked without triggering alarms. Note that the system will not trigger alarms for burglary and non-fire related 24 hour zones but **will** trigger fire alarms while this test is active. This test can only be activated by any user code by entering the corresponding user code and pressing TEST while the burglary portion of the system is disarmed. UL requires that this test be conducted on a weekly basis.

When this test is first activated, the system will sound bells connected to the auxiliary relay for 1 second. The system will send a Walk Test Start report to the central station. The keypads will display "Burg Walk Test in Progress" (alpha keypads) or "TEST Cb" (fixed keypads) and will sound a single beep every 15 seconds while the test remains active.

Open and close each protected door and window in turn. Each action should produce 3 beeps from the keypad. Walk in front of any motion detectors. Listen for three beeps when the detector senses movement. The keypad will display the zone number and alpha descriptor while a door or window remains open or while a detector remains activated.

To end this test, enter any user code and press OFF. An end-of-walk test message will be sent to the central station.

### **Armed Burglary System Test**



1. Alarm messages will be sent to the central station during the following tests. Notify the central station that a test will be in progress.
2. A display of "COMM. FAILURE" indicates a failure to communicate (no kiss-off by the receiver at the central station after the maximum number of transmission attempts is tried). If this occurs, verify that the phone line is connected, the correct report format is programmed, etc.

1. Fault and restore every fire and 24-hour sensor in turn. Arm the system and fault each burglary zone. Silence alarm sounder(s) each time by entering the code and pressing OFF. Check that Entry/Exit delay zones provide the assigned delay times. Verify that the proper local indications and central station reports are provided for all zones.

2. Check the keypad-initiated alarms, if programmed, by pressing the Panic keys (\* & #, 1 & \*, and/or 3 & #). If the system has been programmed for audible emergency, the keypad will emit a loud, steady alarm sound. The word ALARM and a descriptor "07" will be displayed for \* and #. (if 1 and \* are pressed, a "95" will be displayed; if 3 and # are pressed, a "96" will be displayed). Silence the alarm by entering the User Code and pressing OFF. If the system has been programmed for silent panic, there will be no audible alarms or displays. A report will be sent to the central station, however.
3. Notify the central station that all tests are finished and verify results with them.

## **Trouble Conditions (See Troubleshooting Guide also)**

### **General Information**

The word "CHECK" on the Keypad's display, accompanied by a rapid "beeping" at the Keypad, indicates that there is a trouble condition in the system. The audible warning sound can be silenced by entering any User code + OFF. Instruct users to call for service immediately upon seeing any of the following messages.

### **"Check" and "Battery" Displays**

When the problem has been corrected, the display can be cleared by entering the OFF sequence (code plus OFF key) twice.

- **A display of "CHECK"** accompanied by a zone number means there is an open circuit condition on a fire zone, or that there is a system trouble condition such as an earth ground or telephone line fault.
- **A display of "BAT"** (Fixed-word keypads) or **"SYSTEM LO BAT"** (Alpha keypads) **with no zone number** indicates that the system's main standby battery is weak.

### **Telephone Line Failure**

A display of **Check 11** or **Check 12** (fixed word keypads), or **Check 11: Main Dialer** or **Check 12: Back-Up Dialer** (alpha keypads) indicates that a monitored telephone line has been cut (or disconnected). The keypad will also produce a trouble sound (silence by entering code plus OFF).

### **Power Failure**

Power failure may be exhibited in one of the following ways:

- **If there is no keypad display at all**, operating power for the system has stopped and the system is inoperative.
- **If the message "AC LOSS"** (Alpha keypads) or **"NO AC"** (Fixed-word keypads) **is displayed**, the keypad is operating on battery power only.

### **Other Displays** (Fixed Word displays are in parenthesis)

**Busy-Standby (dI)**. If this remains displayed for more than 1 minute, the system is disabled.

**Modem Comm (CC)** The system is in communication with the central station for change of function or status verification.

**Comm. Failure (FC)** A communication failure has occurred.

**Open Circuit (OC)** The keypad is not receiving signals from the control and sees an open circuit.

**Long Rng Trbl (bF)** Back-up LRR communication failure.

## Turning the System Over to the User

1. Fully explain the operation of the system to the user by going over each of its functions as well as the User's Manual supplied.
2. In particular, explain the operation of each zone (entry/exit, perimeter, interior, fire, etc.). Be sure the user understands how to operate any emergency feature(s) programmed into the system.



In the spaces provided in the User's Manual, record the Entry and Exit Delay times, and those functions that have been programmed into the available pairs of PANIC keys (\* & #, 1 & \*, 3 & #).

3. Make sure the user understands the importance of testing the burglary system at least weekly, following the procedure provided in the User's Manual.

### **TO THE INSTALLER**

Regular maintenance and inspection (at least annually) by the installer and frequent testing by the user are vital to continuous satisfactory operation of any alarm system.

The installer should assume the responsibility of developing and offering a regular maintenance program to the user as well as acquainting the user with the proper operation and limitations of the alarm system and its component parts. Recommendations must be included for a specific program of frequent testing (at least weekly) to insure the system's proper operation at all times.

# Section 17. TROUBLESHOOTING GUIDE

## SYSTEM

SYMPTOM	POSSIBLE CAUSE	REMEDY
<b>1. Low Battery message on keypad.</b>	1. "Bat" or "System Lo Bat" (no zone Nos.)	1. System battery is low or missing.
<b>2. Periodic beep(s) from keypad.</b>	2a. System is in TEST mode. 2b. A supervision CHECK has occurred.	2a. Enter "Code" + OFF to exit TEST mode. 2b. Check the zone indicated. If system zone is displayed, check corresponding connections.
<b>3. Intrusion alarm for no apparent reason.</b>	3a. Protected door or window opened while system armed. 3b. Improper user operation of exit/entry delays. 3c. Magnets located too far from switches, and/or doors and windows not properly aligned.	3a. Check with all occupants of protected home. 3b. Check setting of entry delay . Exit delay is 15 seconds longer than the entry delay time. Remind user of same. 3c. Check all openings for proper switch and magnet orientation.
<b>4. "CHECK" and zone number 1-5 is displayed.</b>	4. Control has sensed a high resistance condition on a loop in one of the hard-wired zones.	4. Check the sensor or the loop wiring in the affected zone. The system will not arm until this condition is corrected (or the affected zone is bypassed).
<b>5. Digital communicator message not being received.</b>	5a. Ademco 5120XM in TEST mode. 5b. Telephone connection not secure. 5c. Digital communicator malfunctioning. 5d. Telephone number in program needs prefix or access code. 5e. Telephone call to central monitoring station requires operator assistance.	5a. Remove from TEST mode. 5b. Check all connections. 5c. Check with a different Ademco 5120XM. 5d. Program prefix or access code into the Ademco 5120XM. 5e. Ademco 5120XM system cannot work in this situation.
<b>6. Does not arm properly.</b>	6. Ready light not on.	6. Check for faulted zones and make intact, or use Bypass arming, if desired.
<b>7. System doesn't respond to keystrokes on keypad.</b>	7a. "CC" or "MODEM COMM" displayed.  7b. "d1" or "System Busy" displayed.  7c. Keypad address setting incorrect.	7a. System is in communication with downloader at central station. Wait until download session is finished. 7b. System has just been powered and is in its one minute initialization. To bypass this time, press '#' + '0'. 7c. Keypads must be set for address 31 (non-addressable mode).

## SMOKE DETECTOR

SYMPTOM	POSSIBLE CAUSE	REMEDY
<b>1. Detector alarms, no apparent reason.</b>	1a. Dust, dirt in sensing chamber.  1b. Improper location.  1c. Unit malfunctioning.	1a. Clean unit's sensing chamber with vacuum cleaner per unit's instructions. 1b. See unit's instructions for locations to avoid. Relocate as necessary. 1c. Replace detector.

## **CONTACTING TECHNICAL SUPPORT**

**PLEASE,**

**Before you call Technical Support, be sure you:**

- **READ THE INSTRUCTIONS!**
- **Check all wiring connections.**
- **Determine that the power supply and/or backup battery are supplying proper voltages.**
- **Verify your programming information where applicable.**
- **Note the proper model number of this product, and the version level (if known) along with any documentation that came with the product.**
- **Note your ADEMCO customer number and/or company name.**

**Having this information handy will make it easier for us to serve you quickly and effectively.**

You may contact Technical Support via Toll-Free FAX. Please include your return FAX number. You will receive a reply within 24 hours. You may also contact Technical Support via modem to ATLAS-BBS, Technical Support's Electronic Bulletin Board System. Replies are posted within 24 hours.

East Coast Technical Support: 1-800-645-7492 (8 a.m.-6 p.m. E.S.T.)

West Coast Technical Support: 1-800-458-9469 (8 a.m.-5 p.m. P.S.T.)

Technical Support FAX Number: 1-800-447-5086

ATLAS-BBS Electronic Bulletin Board System: 1-516-496-3980  
(1200 - 9600 Baud, 8 Data Bits, 1 Start/Stop Bit, No Parity)

ATLAS FAX - Automated Fax Retrieval System: 1-800-573-0153

1-516-921-6704/Ext. 1667

ADEMCO World Wide Web Page - [HTTP://WWW.ADEMCO.COM](http://WWW.ADEMCO.COM)

Internet E-Mail Address - [Ademco\\_Tech\\_SPRT@Ademco-165.Ademco.com](mailto:Ademco_Tech_SPRT@Ademco-165.Ademco.com)

## Section 18.

# SPECIFICATIONS & ACCESSORIES

## Specifications-----

### SECURITY CONTROL

**1. Physical:** 18" H x 14-1/2" W x 4.3" D

**2. Electrical:**

VOLTAGE INPUT: From built-in transformer supplying 18VAC for 5120XM and 30VAC for PS24 Power Supply Module. Transformer requires nominal 120V, 2.5A input.

RECHARGEABLE BACK-UP BATTERY: (2) 12VDC, 7AH to 17.2AH (Gel type) connected to PS24 Power Supply Module.

Charging Voltage: 27.0 – 27.6VDC from PS24 Power Supply..

BELL OUTPUT: 12V, 1.0 Amp output should be connected to a PS24 Power Supply Module input (but can power 12V indicating devices instead, if desired). Selectable for Style Y EOLR supervision (using 610-7 EOLR) or no supervision. PS24 provides separate 1.7A/24VFW output.

RELAY OUTPUT: One Auxiliary Relay Output selectable for wet form C output rated at 12V/400mA standby max/1A alarm max, or dry form C output with contacts rated at 30VAC/VDC, 2A max resistive loads.

OUTPUT POWER: Combined Auxiliary Power #1, Auxiliary Power #2, and Auxiliary Relay standby currents cannot exceed 400mA.

Combined above currents plus Bell Output current cannot exceed 1.0A. (Bell output current is 50mA if connected to PS24 Power Supply Module.)

STANDBY TIME: (see Table in the *FINAL POWER UP* section)

FUSING: PTC circuit protectors on battery input and on Aux. Pwr #1, Aux. Pwr #2, Aux. Relay, and Bell outputs.

**3. Telephone Interface:**

Two telephone interfaces with programmable line fault supervision

Line Seize: Double Pole

Ringer Equivalence: 0.7B

FCC Registration No.: AC398U-68192-AL-E

TLM Threshold: Good when tip-ring voltage exceeds 2V;

Faulted when less than 2V.

**4. Communication:**

FORMATS SUPPORTED:

**Ademco Express,**

10 characters/sec, DTMF (TouchTone) Data Tones, 1400/2300Hz ACK, 1400Hz KISSOFF.

**Ademco Contact ID Reporting,**

10 characters/sec., DTMF (TouchTone) Data Tones, 1400/2300Hz ACK, 1400Hz KISSOFF.

**Ademco Low Speed,** 10 pulses/sec, 1900Hz Data Tone, 1400Hz ACK/KISSOFF.

**Radionics/SESCOA,** 20 pulses/sec, 1800Hz Data Tone, 2300Hz ACK/KISSOFF. Can report 0–9, B–F

**5. Maximum Zone Resistance:**

Zones 1–4 = 300 ohms (excluding EOLR); Zone 5 = 100 ohms (excluding EOLR)



**KEYPADS SUPPORTED**

Up to four of the following keypads for audible/visual annunciation and control (depending on Aux. Pwr #1 and #2 loading):

6137/6137R Fixed English keypad

6139/6139R Alpha keypad

**AGENCY LISTINGS****Fire:**

- UL864-NFPA 72 Local, Central Station and Remote Station fire alarm service
- FM Pending
- CSFM Pending

**Burglary:**

- UL609 Grade A Local Mercantile Premises and Mercantile Safe and Vault
- UL611/UL1610 Grade B Central Station Burglary Alarm Service (Grade A service will be available with future 7720PLUS LORRA)
- UL365 Grade A Police Connect Burglary Alarm Service

**Accessories (Compatible Devices)** -----

**UL Listed 24V Alarm  
Indicating Devices  
(Connect to PS24  
Output)**

**Horn/Strobes:**

System Sensor	MASS2415ADA
System Sensor	MASS2475ADA
System Sensor	MASS24110ADA
System Sensor	MASS241575ADA
Wheelock	MT-24-LS-VFR & MT4-24-LS-VFR
Wheelock	MT-24-LSM-VFR & MT4-24-LSM-VFR
Wheelock	MT-24-MS-VFR & MT4-24-MS-VFR
Wheelock	MT-24-IS-VFR & MT4-24-IS-VFR
Gentex	SHG24-15-1
Gentex	SHG24-1575
Gentex	SHG24-110-1

**Strobes:**

System Sensor	SS2415ADA
System Sensor	SS241575ADA
System Sensor	SS2475ADA
System Sensor	SS24110ADA
Wheelock	LS1M-24-VFR
Wheelock	MS1-24-VFR
Gentex	GXS-4-15-1
Gentex	GXS-4-1575
Gentex	GXS-4-110-1

**Compatible 2-Wire  
Smoke Detectors**

<b>Detector Type</b>	<b>Device Model #</b>
Ionization, direct wire	System Sensor 1100
Ionization with B110LP base	System Sensor 1151
Ionization, direct wire	System Sensor 1400
Ionization w/B401B base	System Sensor 1451
Ionization duct detect. w/DH400 base	System Sensor 1451DH
Photoelectric, direct wire	System Sensor 2100
Photoelectric w/heat sensor, direct wire	System Sensor 2100T
Photoelectric w/B110LP base	System Sensor 2151
Photoelectric w/heat sensor, direct wire	System Sensor 2300T
Photoelectric, direct wire	System Sensor 2400
Photoelectric w/heat sensor, direct wire	System Sensor 2400TH
Photoelectric w/B401B base	System Sensor 2451
Photoelectric w/heat sensor & B401Bbase	System Sensor 2451TH
Photoelectric duct detector w/DH400 base	System Sensor 2451

**Compatible 4-Wire  
Smoke/Combustion  
Detectors**

<b>1412</b>	<i>System Sensor, 4-wire ionization products of combustion detector</i>
<b>2412</b>	<i>System Sensor, 4-wire photoelectric smoke detector</i>
<b>2412TH</b>	<i>System Sensor, 4-wire photoelectric smoke detector w/135° F (57° C) heat detector</i>
<b>2112/24T</b>	<i>System Sensor low-profile 4-wire photoelectric smoke detector w/135° F (57° C) heat detector</i>

## SUMMARY OF SYSTEM COMMANDS

Enter Program Mode	Enter Master code + [Code] key + 0, or simultaneously press * & # within 50 seconds of power up.	Requires 6139/6139R keypad. Enter *98 or *99 to exit.
View Faulted Zones	Press the [Ready] key.	Displays faulted zones when burglary system "not ready" to arm.
Arm Burglary Protection	Enter User code + desired arming mode key (Away, Stay, Maximum, or Instant)	Arms burglary protection in selected mode.
Quick Arm (if programmed)	Press [#] + desired arming mode key (Away, Stay, Maximum, or Instant)	Arms system in selected mode without the use of User Code. Code must always be used to disarm.
Disarm Burglary Protection	Enter User code + [Off] key.	
Silence Alarm, Supervisory, or Trouble Sounds	Enter User code + [Off] key.	Keypad displays zone numbers of faulted zones/zones in trouble
Reset Smoke Detectors and Displays	Enter User code + [Off] key a second time.	Will reset only if condition (alarm/trouble) has been corrected.
Manually Activate Panic Alarms	Press and hold remote keypad panic key(s) for at least two seconds.	Panic zones (95, 96 and 07) must be enabled.
Trigger Duress Alarm	Enter User 8's User Code to arm or disarm.	Arms/disarms normally, but sends a silent alarm message to the central station (report code must be programmed).
Bypass	Enter User code + [Bypass] key + Zone # to be bypassed.	Master code can bypass any zone. User 2-6 can bypass burglary zones only.
Remove Zone Bypass	Fire & system zones: Enter Master code + [Bypass] key + Zone # to unby-pass.  Remaining (burglary) zones: Enter User code + [Off] key	
Chime Mode	Enter User code + [Chime] key to turn on. Re-enter User code + [Chime] to turn off.	Causes keypads to beep when doors/windows are opened.
Activate Fire Drill Command	Master or User code 2 + [#] + 69.	Enter User code + [Off] to turn off.
Activate Fire Walk Test	Enter Master code + [#] + 68.	Enter User code + [Off] to turn off.
Activate Burglary Walk Test	Enter User code + [Test] key.	Enter User code + [Off] to turn off.
Assign, Change, or Delete User Code	Enter Master code (or User 2 code) + new user # + new user code.	When deleting, stop after entering new user #.

# REGULATORY AGENCY STATEMENTS

The 5120XM can provide UL listed local, central, or remote station fire alarm, local or central station burglary alarm, and police connected burglary alarm service. Some general comments about these installations are provided below.

## **UL864/NFPA72A Local Fire**

- Configure the bell output for EOLR supervision and wire polarized fire alarm indicators to it. Program the bell for pulsed operation when burglary protection will be installed. Burglary sounders should be wired to the auxiliary relay output.

## **UL864/NFPA72 Central and Remote Station**

- Enable both main and back-up dialers and connect both dialers to separate telephone lines. Program both dialers for line fault supervision.
- Program the panel to send fire alarm, fire supervisory (if used), trouble, AC loss, restore, normal dialer test, and off-normal test reports. Also program the panel to transmit test reports every 24 hours.
- Size the backup battery for 24 hours of standby time (central station installations) or for 60 hours of standby time (remote station installations).

## **UL609 Grade A Local Mercantile Premises/Local Mercantile Safe and Vault**

- Wire the ADEMCO AB12 grade A bell/box to the auxiliary relay. The relay must be configured as 12V output and be programmed to activate on burglary alarms, to provide 16 minute or longer timeout, and to provide arming ding. Bell wires must be run in conduit.
- Attach a door tamper switch (supplied) to the 5120XM back-box. For safe and vault installations, a shock sensor (not supplied) and a pry-off tamper contact (not supplied) must also be attached to the back-box [MOUNTING THE CABINET].
- Wire the bell box and 5120XM cabinet door tamper (and shock sensor, if used) to zone 4. Select the zone 4 alternate tamper function and assign zone 4 a day trouble/night alarm response.
- Entry delays must not exceed 45 seconds and exit delays must not exceed 60 seconds.

## **UL 365 Police Station Connected Burglar Alarm**

- Follow the instructions for UL 609 local mercantile installations
- You may use the main dialer alone, or both main and back-up dialers.
- When using the main dialer alone, program it to send burglary alarm, low battery and normal dialer test reports. Program the control panel to send dialer test reports every 24 hours.
- When using both main and backup dialers, program both dialers for line fault supervision. Program the control panel to send burglary alarm, trouble, and low battery reports.

## **UL611/UL 1610 Grade B Central Station Burglar Alarm**

- Follow the instructions for UL 609 local installations
- You may use the main dialer alone. Program the control panel to send burglary alarm, opening/closing, normal dialer test, and low battery reports. Program the control panel to send normal dialer test reports every 24 hours.

### **FEDERAL COMMUNICATIONS COMMISSION (FCC) Part 15 STATEMENT**

This equipment has been tested to FCC requirements and has been found acceptable for use. The FCC requires the following statement for your information:

This equipment generates and uses radio frequency energy and if not installed and used properly, that is, in strict accordance with the manufacturer's instructions, may cause interference to radio and television reception. It has been type tested and found to comply with the limits for a Class B computing device in accordance with the specifications in Part 15 of FCC Rules, which are designed to provide reasonable protection against such interference in a residential installation. However, there is no guarantee that interference will not occur in a particular installation. If this equipment does cause interference to radio or television reception, which can be determined by turning the equipment off and on, the user is encouraged to try to correct the interference by one or more of the following measures:

- If using an indoor antenna, have a quality outdoor antenna installed.
- Reorient the receiving antenna until interference is reduced or eliminated.
- Move the radio or television receiver away from the receiver/control.
- Move the antenna leads away from any wire runs to the receiver/control.
- Plug the receiver/control into a different outlet so that it and the radio or television receiver are on different branch circuits.

If necessary, the user should consult the dealer or an experienced radio/television technician for additional suggestions. The user or installer may find the following booklet prepared by the Federal Communications Commission helpful: "Interference Handbook"

This booklet is available from the U.S. Government Printing Office, Washington, DC 20402.

*The user shall not make any changes or modifications to the equipment unless authorized by the Installation Instructions or User's Manual. Unauthorized changes or modifications could void the user's authority to operate the equipment.*

### **FEDERAL COMMUNICATIONS COMMISSION (FCC) Part 68 STATEMENT**

This equipment complies with Part 68 of the FCC rules. On the front cover of this equipment is a label that contains, among other information, the FCC registration number and ringer equivalence number (REN) for this equipment. If requested, this information must be provided to the telephone company.

This equipment uses the following jacks: An RJ31X is used to connect this equipment to the telephone network.

The REN is used to determine the quantity of devices which may be connected to the telephone line. Excessive RENs on the telephone line may result in the devices not ringing in response to an incoming call. In most, but not all areas, the sum of the RENs should not exceed five (5.0). To be certain of the number of devices that may be connected to the line, as determined by the total RENs, contact the telephone company to determine the maximum REN for the calling area.

If this equipment causes harm to the telephone network, the telephone company will notify you in advance that temporary discontinuance of service may be required. If advance notice is not practical, the telephone company will notify the customer as soon as possible. Also, you will be advised of your right to file a complaint with the FCC if you believe necessary.

The telephone company may make changes in its facilities, equipment, operations, or procedures that could affect the operation of the equipment. If this happens, the telephone company will provide advance notice in order for you to make the necessary modifications in order to maintain uninterrupted service.

If trouble is experienced with this equipment, please contact the manufacturer for repair and warranty information. If the trouble is causing harm to the telephone network, the telephone company may request you remove the equipment from the network until the problem is resolved.

There are no user serviceable components in this product, and all necessary repairs must be made by the manufacturer. Other repair methods may invalidate the FCC registration on this product.

This equipment cannot be used on telephone company-provided coin service. Connection to Party Line Service is subject to state tariffs.

This equipment is hearing-aid compatible.

When programming or making test calls to an emergency number, briefly explain to the dispatcher the reason for the call. Perform such activities in the off-peak hours; such as early morning or late evening.

## **WARNING**

### **THE LIMITATIONS OF THIS ALARM SYSTEM**

While this System is an advanced design security system, it does not offer guaranteed protection against burglary, fire or other emergency. Any alarm system, whether commercial or residential, is subject to compromise or failure to warn for a variety of reasons. For example:

- Intrusion detectors (e.g., passive infrared detectors), smoke detectors, and many other sensing devices will not work without power. Battery-operated devices will not work without batteries, with dead batteries, or if the batteries are not put in properly. Devices powered solely by AC will not work if their AC power supply is cut off for any reason, however briefly.
- Signals sent by wireless transmitters may be blocked or reflected by metal before they reach the alarm receiver. Even if the signal path has been recently checked during a weekly test, blockage can occur if a metal object is moved into the path.
- A user may not be able to reach a panic or emergency button quickly enough.
- While smoke detectors have played a key role in reducing residential fire deaths in the United States, they may not activate or provide early warning for a variety of reasons in as many as 35% of all fires, according to data published by the Federal Emergency Management Agency. Some of the reasons smoke detectors used in conjunction with this System may not work are as follows. Smoke detectors may have been improperly installed and positioned. Smoke detectors may not sense fires that start where smoke cannot reach the detectors, such as in chimneys, in walls, or roofs, or on the other side of closed doors. Smoke detectors also may not sense a fire on another level of a residence or building. A second floor detector, for example, may not sense a first floor or basement fire. Finally, smoke detectors have sensing limitations. No smoke detector can sense every kind of fire every time. In general, detectors may not always warn about fires caused by carelessness and safety hazards like smoking in bed, violent explosions, escaping gas, improper storage of flammable materials, overloaded electrical circuits, children playing with matches, or arson. Depending on the nature of the fire and/or location of the smoke detectors, the detector, even if it operates as anticipated, may not provide sufficient warning to allow all occupants to escape in time to prevent injury or death.
- Passive Infrared Motion Detectors can only detect intrusion within the designed ranges as diagrammed in their installation manual. Passive Infrared Detectors do not provide volumetric area protection. They do create multiple beams of protection, and intrusion can only be detected in unobstructed areas covered by those beams. They cannot detect motion or intrusion that takes place behind walls, ceilings, floors, closed doors, glass partitions, glass doors, or windows. Mechanical tampering, masking, painting or spraying of any material on the mirrors, windows or any part of the optical system can reduce their detection ability. Passive Infrared Detectors sense changes in temperature; however, as the ambient temperature of the protected area approaches the temperature range of 90° to 105°F (32° to 40°C), the detection performance can decrease.
- Alarm warning devices such as sirens, bells or horns may not alert people or wake up sleepers if they are located on the other side of closed or partly open doors. If warning devices are located on a different level of the residence from the bedrooms, then they are less likely to waken or alert people inside the bedrooms. Even persons who are awake may not hear the warning if the alarm is muffled by noise from a stereo, radio, air conditioner or other appliance, or by passing traffic. Finally, alarm warning devices, however loud, may not warn hearing-impaired people.
- Telephone lines needed to transmit alarm signals from a premises to a central monitoring station may be out of service or temporarily out of service. Telephone lines are also subject to compromise by sophisticated intruders.
- Even if the system responds to the emergency as intended, however, occupants may have insufficient time to protect themselves from the emergency situation. In the case of a monitored alarm system, authorities may not respond appropriately.
- This equipment, like other electrical devices, is subject to component failure. Even though this equipment is designed to last as long as 20 years, the electronic components could fail at any time.

The most common cause of an alarm system not functioning when an intrusion or fire occurs is inadequate maintenance. This alarm system should be tested weekly to make sure all sensors and transmitters are working properly. The security keypad (and remote keypad) should be tested as well.

Wireless transmitters (used in some systems) are designed to provide long battery life under normal operating conditions. Longevity of batteries may be as much as 4 to 7 years, depending on the environment, usage, and the specific wireless device being used. External factors such as humidity, high or low temperatures, as well as large swings in temperature, may all reduce the actual battery life in a given installation. This wireless system, however, can identify a true low battery situation, thus allowing time to arrange a change of battery to maintain protection for that given point within the system.

Installing an alarm system may make the owner eligible for a lower insurance rate, but an alarm system is not a substitute for insurance. Homeowners, property owners and renters should continue to act prudently in protecting themselves and continue to insure their lives and property.

We continue to develop new and improved protection devices. Users of alarm systems owe it to themselves and their loved ones to learn about these developments.

## ADEMCO LIMITED WARRANTY

Alarm Device Manufacturing Company, a Division of Pittway Corporation, and its divisions, subsidiaries and affiliates ("Seller"), 165 Eileen Way, Syosset, New York 11791, warrants its products to be in conformance with its own plans and specifications and to be free from defects in materials and workmanship under normal use and service for 24 months from the date stamp control on the product or, for products not having an Ademco date stamp, for 12 months from date of original purchase unless the installation instructions or catalog sets forth a shorter period, in which case the shorter period shall apply. Seller's obligation shall be limited to repairing or replacing, at its option, free of charge for materials or labor, any product which is proved not in compliance with Seller's specifications or proves defective in materials or workmanship under normal use and service. Seller shall have no obligation under this Limited Warranty or otherwise if the product is altered or improperly repaired or serviced by anyone other than Ademco factory service. For warranty service, return product transportation prepaid, to Ademco Factory Service, 165 Eileen Way, Syosset, New York 11791.

THERE ARE NO WARRANTIES, EXPRESS OR IMPLIED, OF MERCHANTABILITY, OR FITNESS FOR A PARTICULAR PURPOSE OR OTHERWISE, WHICH EXTEND BEYOND THE DESCRIPTION ON THE FACE HEREOF. IN NO CASE SHALL SELLER BE LIABLE TO ANYONE FOR ANY CONSEQUENTIAL OR INCIDENTAL DAMAGES FOR BREACH OF THIS OR ANY OTHER WARRANTY, EXPRESS OR IMPLIED, OR UPON ANY OTHER BASIS OF LIABILITY WHATSOEVER, EVEN IF THE LOSS OR DAMAGE IS CAUSED BY THE SELLER'S OWN NEGLIGENCE OR FAULT.

Seller does not represent that the products it sells may not be compromised or circumvented; that the products will prevent any personal injury or property loss by burglary, robbery, fire or otherwise; or that the products will in all cases provide adequate warning or protection. Customer understands that a properly installed and maintained alarm may only reduce the risk of a burglary, robbery, fire or other events occurring without providing an alarm, but it is not insurance or a guarantee that such will not occur or that there will be no personal injury or property loss as a result. CONSEQUENTLY, SELLER SHALL HAVE NO LIABILITY FOR ANY PERSONAL INJURY, PROPERTY DAMAGE OR OTHER LOSS BASED ON A CLAIM THE PRODUCT FAILED TO GIVE WARNING. HOWEVER, IF SELLER IS HELD LIABLE, WHETHER DIRECTLY OR INDIRECTLY, FOR ANY LOSS OR DAMAGE ARISING UNDER THIS LIMITED WARRANTY OR OTHERWISE, REGARDLESS OF CAUSE OR ORIGIN, SELLER'S MAXIMUM LIABILITY SHALL NOT IN ANY CASE EXCEED THE PURCHASE PRICE OF THE PRODUCT, WHICH SHALL BE THE COMPLETE AND EXCLUSIVE REMEDY AGAINST SELLER. This warranty replaces any previous warranties and is the only warranty made by Seller on this product. No increase or alteration, written or verbal, of the obligations of this Limited Warranty is authorized.

# INDEX

15-SECOND DIALER DELAY, BURGLARY, 46  
2112/24T photoelectric smoke detector 20, 74  
24-hour Audible Alarm, 51  
24-hour Silent Alarm, 51  
24-Hr. Trouble, 52  
2412, 20, 74  
2412TH, 20, 74  
3+1 and 4+1 Expanded Formats, 43  
3+1 and 4+1 Standard Formats, 43  
3+1 or 4+1 Standard Format, 47, 58  
3-digit number, 36, 37  
4+2 Format, 43  
6137, 6137R, 8, 14  
6139 or 6139R, 8,9,17  
6139TRK, 15

## -A-

AC LOSS REPORT CODE, 47, 58  
AC Power Connections, 30  
AC RESTORE REPORT CODE, 48, 59  
Accessories, 73  
Ademco Contact ID, 9, 43  
Ademco Express, 9, 72  
Ademco Low Speed, 9, 72  
AGENCY LISTINGS, 73  
Alarm Bell Timeout, 27, 54  
alarm output, 25  
ALARM RESTORE REPORT CODE 48, 59  
Alpha, 18  
Alpha descriptor, 36, 38  
Alpha keypad, 8,18  
Alpha Vocabulary List, 37  
Answering machine., 49, 60  
ARM AWAY/STAY REPORT CODE, 48, 59  
Armed Burglary System Test, 68  
Arming Away, 64  
Arming Instant, 64  
Arming Maximum, 64  
ARMING MODES, 65  
Arming Stay, 64  
AUDIBLE EXIT WARNING, 55  
auxiliary relay output, 28

## -B-

Back-Up Battery, 31  
Basic Hardwired Zones, 8  
battery capacity formula, 35  
BATTERY SELECTION TABLE, 34  
Battery Size, 31  
Battery Test, 66  
bells, 25  
block, 14  
Burglary Walk Test, 67  
BYPASS REPORT CODE, 47, 58  
BYPASS RESTORE REPORT CODE, 48, 59  
Bypassing Zones, 64

## -C-

Cabinet Attack Resistance, 10  
cabinet lock, 10  
CANCEL REPORT CODE, 48, 59  
CHARACTER (ASCII) CHART, 41  
CHARACTER CHART, 36

CHARACTER LIST, 39  
Charging Voltage, 72  
Chime Mode, 64  
Communication, 72  
communication failure, 69  
Communication Formats Supported, 9  
Compatible 2-Wire Smoke Detectors, 21  
compatible alarm indicating devices, 25  
CONFIRMATION OF ARMING DING FOR BELL, 56  
Contact ID, 44, 47, 58  
CONTACT ID EVENT CODES, 44  
Contact ID Reporting, 72  
control cabinet, 10  
CUSTOM ALPHA EDITING, 59  
Custom Words, 39, 41

## -D-

Default Descriptor , 37  
Dialer Operation, 13  
DIALER PROGRAMMING, 55  
Dialer Test, 66  
Disarmed, Not Ready, 64  
Disarming, 64  
DOWNLOAD INFORMATION, 60  
DOWNLOAD PHONE NUMBER, 60  
DOWNLOAD PHONE NUMBER , 49  
Downloading, 49, 60  
Duress Code, 8

## -E-

Enabling the Dialer Outputs, 12  
Entering Program Mode, 17  
Entry Delay, 50, 70  
Entry/Exit Burglary, 50  
EOL resistor, 15, 19, 20, 23  
Exit Delay, 50, 70  
EXIT PROGRAMMING MODE, 60  
Expanded or 4+2 Format, 47, 58  
external sounder options, 25

## -F-

Factory Defaults, 18  
FCC, 77  
Fire Alarm, 51  
fire alarm sounding, 21  
Fire Alarm Verification, 21  
Fire Drill Test (Master or User 2 code + [, ] + 69)  
Fire Sprinkler Supervisory, 52  
Fixed-Word Keypads, 8  
FORCED BYPASS FUNCTION, 53  
formats, 42

## -G-

General Information, 42  
Grade A Mercantile Premises Listing, 10  
Grade A Mercantile Safe and Vault Listing, 11  
GROUP RESTORES FOR TROUBLE & BYPASS, 48,59  
handshake, 42  
HAYES modem specified by Ademco, 9  
HAYES Modem., 61



**-I-**  
IBM compatible Personal Computer, 17,61  
INITIALIZE DOWNLOAD ID AND  
SUBSCRIBER ACCT. No. FOR DOWNLOADING,  
49, 60  
interactive programming, 21  
Interior w/Delay, 51  
Interior, Follower, 50

**-K-**  
Keypad Panic Keys, 8  
keypads, 14, 15  
KEYPADS SUPPORTED, 73  
kissoff, 42

**-L-**  
Lock, 11  
LOW BAT REPORT CODE, 47, 58  
LOW BAT RESTORE REPORT CODE, 48, 59  
Low Battery message, 70  
LRR communication failure, 69

**-M-**  
Magnets, 70  
MAIN DIALER PULSE/TONE SELECTION., 45  
main PC board, 10  
MASTER CODE, 53  
MISCELLANEOUS OPTIONS, 54  
modem, 17  
monitored telephone line, 68

**-N-**  
No. A77-716B, 19  
NORMAL TEST REPORT CODE, 47, 58  
NO. OF REPORTS IN ARMED PERIOD, 49, 60

**-O-**  
One Man Fire Walk Test, 66  
OPEN/EXIT ALARM REPORT CODE, 47, 58  
Optima 24 Plus FAX96 Modem, 61  
OUTPUT TO LONG RANGE RADIO, 53

**-P-**  
PABX ACCESS CODE, 55  
PABX ACCESS CODE., 45  
Perimeter Burglary, 50  
PERIODIC TEST REPORT, 46, 56  
Power Failure, 69  
PRIMARY PHONE No., 45, 55  
Program upload time: 1 minute 30 seconds for a  
complete program. Program download time, 62  
PS24 power supply module, 31

**-Q-**  
QUICK ARM, 64  
QUICK ARM ENABLE, 53

**-R-**  
Radionics/SESCOA, 72  
Recommendations For Proper Intrusion  
Protection, 2  
Recommendations For Smoke/Heat Detectors, 2  
REGULATORY AGENCY STATEMENTS, 76  
Relay Connections, 28  
Remote Keypads, 8

REMOTE PROGRAMMING, 61  
Report Code, 57  
report codes, 47, 58  
REPORT FORMAT, 56  
REPORT FORMAT, 46  
RESTORE, 59  
RING DETECTION, 49  
RING DETECTION COUNT FOR  
DOWNLOADING, 60

**-S-**  
SECONDARY PHONE No., 45, 55  
Secondary User Codes, 63  
Sescoa/Radionics, 9  
SESCOA/RADIONICS SELECT, 46, 56  
SET ALL PROGRAM FIELDS TO DEFAULT  
VALUES, 60  
Silent Panic, 65  
SINGLE ALARM SOUNDING PER ZONE, 54  
Single Alarm Sounding per Zone/Armed Period, 27  
sirens, 25  
SMARTMODEM 1200, 61  
Specifications, 72  
SPLIT/DUAL REPORTING, 46, 56  
SUBSCRIBER ACCOUNT. No., 45, 55  
SUMMARY OF SYSTEM COMMANDS, 75  
SYSTEM COMMUNICATION, 42  
system status and restore REPORT CODES, 47,  
48, 58  
System zone assignments, 24

**-T-**  
Technical Support, 71  
Telephone Line, 12  
Telephone Line Supervision, 12  
TOTAL STANDBY/ALARM LOAD  
WORKSHEETS, 32  
trouble condition, 68  
TROUBLE REPORT CODE, 47, 58  
TROUBLE RESTORE REPORT CODE, 48, 59  
TROUBLESHOOTING GUIDE, 70

**-V-**  
V-LINK® Downloading Software Diskette, 62  
V-LINK® Software, 61  
VOCABULARY LIST, 40  
Wiring 2-Wire Smoke Detector, 20  
Wiring Burglary and Panic Devices, 19

**-Z-**  
Zone 4 Tamper Configuration, 20  
ZONE ASSIGNMENT/ALARM REPORT CODES,  
56  
Zone Descriptors, 38  
Zone Descriptors), 40  
Zone Not Used, 50  
Zone Programming, 18  
zone type, 22  
Zone Type Defaults, 57  
Zone types, 50

# NOTES





**ALARM DEVICE MANUFACTURING CO.**  
A DIVISION OF PITTWAY CORPORATION

**165 Eileen Way, Syosset, New York 11791**

**Copyright © 1996 PITTWAY CORPORATION**